

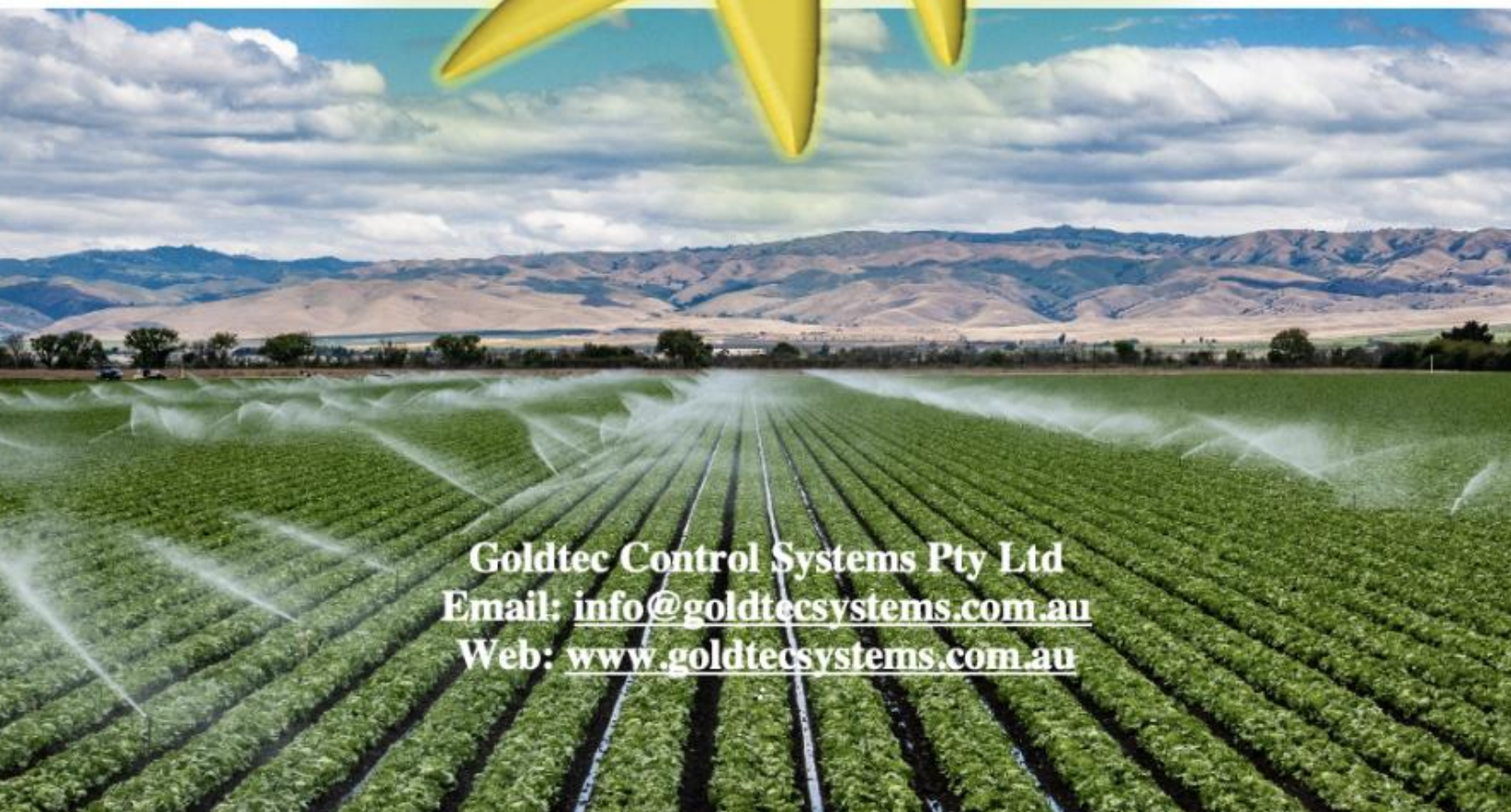

SAPIR 2
SPOT 3
User & Installation Guide



Goldtec Control Systems Pty Ltd
Email: info@goldtecsystems.com.au
Web: www.goldtecsystems.com.au



Document version V3.02

Contents

1. Introduction	4
.....	5
2. The system structure	6
2.1 Hardware	6
2.2 Interfaces	7
3. How to connect the interfaces	9
4. Communication	9
4.1 Connection to the server	9
4.2 Cellular modem	11
4.3 WI-FI	11
5. Communication with the controller	12
5.1 Available internet connection	12
5.2 No internet connection	12
6. First introduction and downloading	14
6.1 What is SPOT?	14
6.2 Downloading from the Android operating system	14
6.3 Downloading from the IOS operating system	14
7. Connecting to the SAPIR2	15
8.1 Connecting with SPOT to the server (online)	15
8.2 Connecting with SPOT to the SAPIR2 (Wi-Fi Direct).....	16
8. Selecting controller from the list (in case you have more than one).....	17
7.1 Controller options list	18
9. Home Page.....	19
10.1 Home page Option list	20
10. Irrigation	21
11.1 New irrigation program	22
11.1.2 Irrigation program – from the main screen of the irrigation program	23
Water dosage -	24
Schedule -	25
Cycles -	26
11. Status	33
12. Event log	34

14. Interfaces	35
15. I/O (Inputs / Outputs).....	36
16. Flushing	37
17. Accs (accumulations)	38
18. Flow	39
19. Sensors.....	40
20. Evaporation.....	41
21. Alarms.....	42
22. Settings.....	43
22.1 System	44
22.2 Line	48
22.3 Main valve	49
22.4 Valve	50
22.5 Valves group	51
22.6 Water meter.....	52
22.7 Fertilizer.....	53
22.8 Filtration site	54
22.9 Analog sensor.....	55

1. Introduction

The SAPIR 2 is the next generation of central control irrigation systems. It allows combining various technologies to suit each project's specific needs. It is an Internet-enabled controller that gives the user the ability to control and monitor everything from anywhere at any time, using his PC or Smartphone.

The SAPIR 2 is the perfect solution for small to medium irrigation projects with a single irrigation head, suitable for both simple and most demanding applications.



SAPIR 2 – Irrigation Network Max 32 Outputs

- Main valve -1
- Irrigation valves -32
- Fertilization valves -4
- Fertilization Booster -1
- Filters-31
- Downstream valve -1
- Sattellites-16

Sapir 2 Configuration	
Sites	Max Quantity
Irrigation line	1
Local Fertilization site	1
Local Filtration site	1
Outputs	
Main valve	1
Irrigation valves	32
Injectors	4
Booster	1
Agitators	4
Filters	31
Downstream valve	1
Satellites	16
Maximum Total number of outputs	32

SAPIR 2 – Irrigation Network Max 30 Digital and 48 Analog inputs

- Water meter-1
- Free water meters -8
- Pressostat-1
- Fertilization meters -4
- DP-1
- Contacts-16
- Analog inputs-48

Sapir 2 Configuration	
Sites	Max Quantity
Irrigation line	1
Local Fertilization site	1
Local Filtration site	1
Digital Inputs	
Line Water meter	1
Free water meters	8 *
* 1 Line water meter + 7 free water meters Or 8 free water meters.	
Fertilization meters	4
Pressure meter	1
DP	1
Contacts	16
Maximum Total number of digital inputs	30
Analog inputs	48

2. The system structure

The following chapter contains a short explanation of the system structure.

2.1 Hardware

Sapir 2 DC- HARDWARE

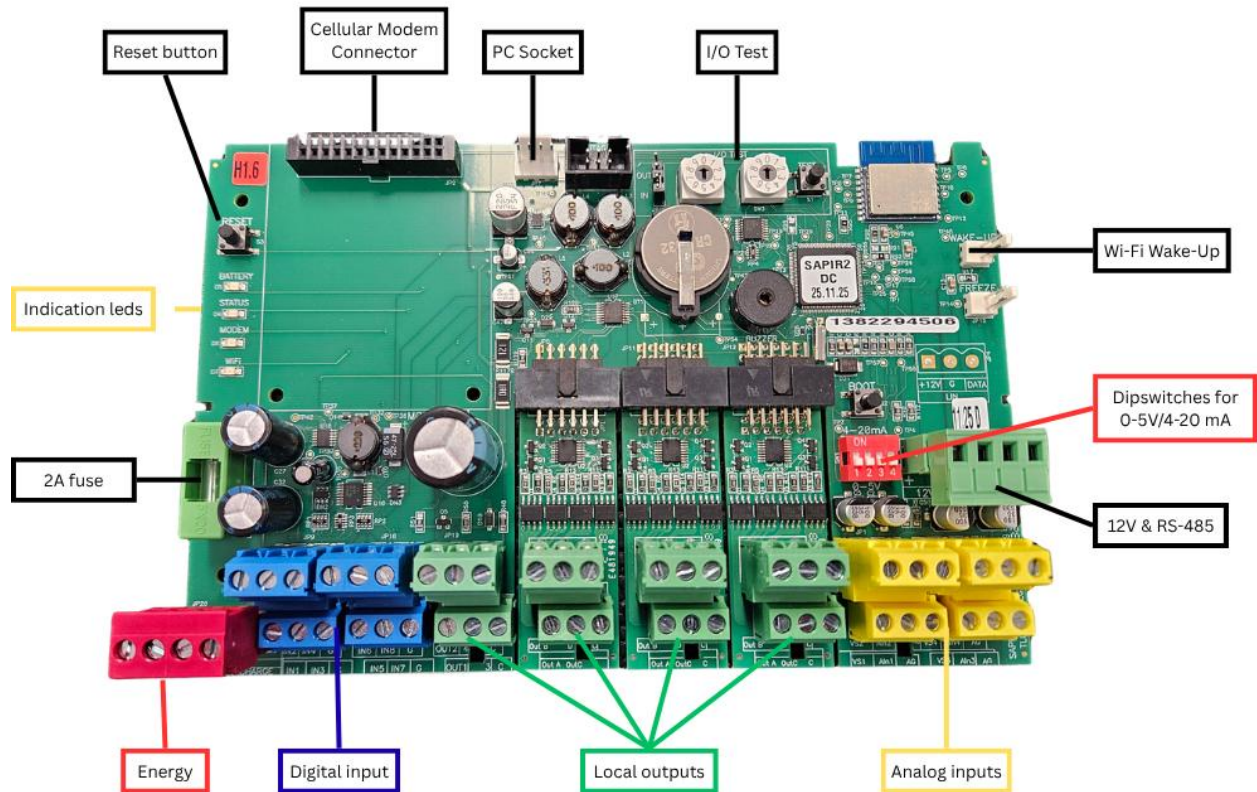

Sapir 2 AC- HARDWARE

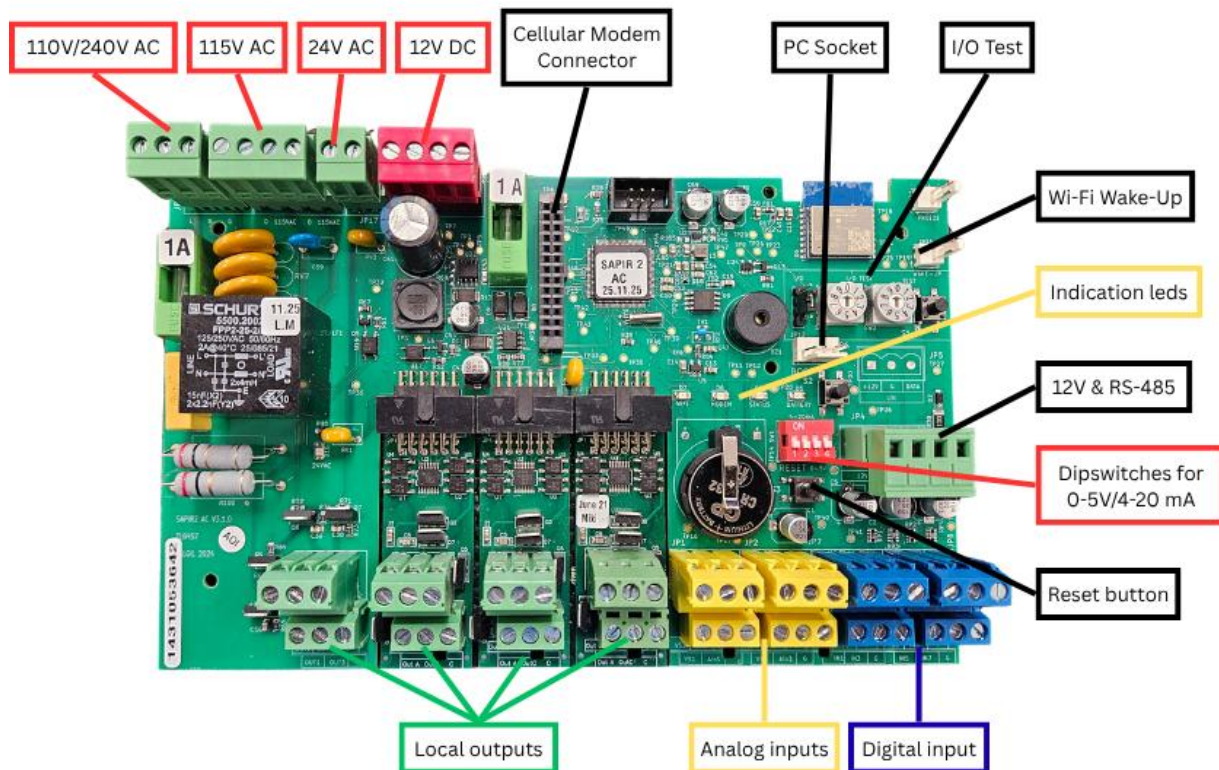

2.2 Interfaces - The following schema describes the principal structure of the SAPIR 2 interfaces system.

The interfaces function is to communicate between the external I/O devices such as – RTU's, analog sensors, weather station.... and the CPU.

Note – the on board local I/O's doesn't have an external interface, it's included in the SAPIR 2 board hardware and software.

For example – the steps of an opening command to valve number 3, which is connected to RTU RF number 2 in output 1:

1. The CPU will send the opening command to the interface / master RF.
2. The interface / master RF will send the command to RTU number 2.
3. RTU number 2 will open output 1.

When use digital or analog sensor, the same logic works but the other way around, meaning that the sensor is connected to an input in the RTU and when the sensor send a signal to the RTU, it sends it to the interface and the interface to the CPU.

Communication with the physically connected external interfaces is done by RS-485 communication protocol.

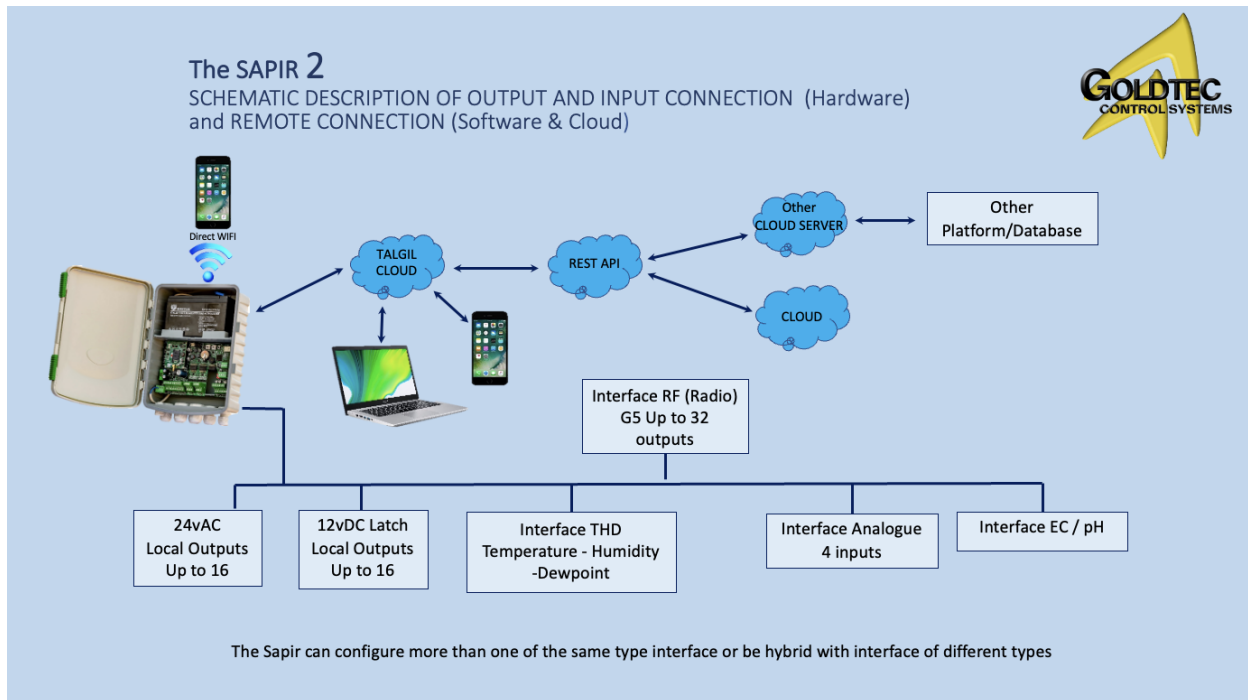

3. How to connect the interfaces

All the external interfaces will connect to the same terminal in the SAPIR2, the terminal is divided in two, the left part is made to supply energy (12V) to the interfaces and the right part is for communication (RS-485). Polarity is important when connecting energy and communication to the interface.

all the interfaces (except “PESSL”) will be connected by communication (RS-485) cable to the SAPIR2, but **NOT** all of them will be energized from it, it depends on the interface type and installation distances from the **SAPIR 2**. if the interface is installed near the controller it can be energized by the **SAPIR 2**, if not, the interface should be energized from a local power supply such as charger or solar panel and rechargeable battery.

Note – interface **2 WIRE** will be powered always from an external power supply and never directly from the **SAPIR 2** 12V terminal.

Wiring the interfaces terminal in the SAPIR2:

Note: All wiring in the above terminal should be connected in the same way in the interfaces.

- Make sure to set the interface address number exactly like in the **SAPIR 2** image.

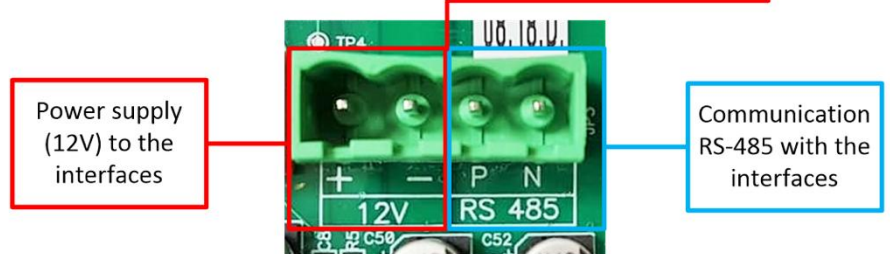

4. Communication

The following chapter contains an explanation of the system's communication with the server.

4.1 Connection to the server

Connecting the controller to the server allows the user to program and monitor the controller from everywhere at any time, moreover, it allows multiple users access to a certain controller and/or access with a certain user name to multiple controllers.

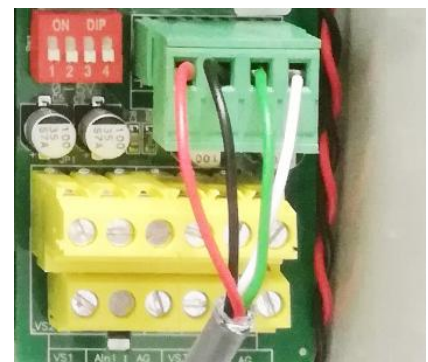

All the communication between the user's pc / smartphone and the controller is happening in the server (except while using WIFI Direct), for example, if a user changes a certain irrigation program from his computer using the CONSOLE, the changes are done in the server, and the information passes to the controller.

In addition, all the information from the controller (online controller) is saved in TALGIL's server (cloud).



There are 2 ways to connect the SAPIR 2 to the TALGIL server, The first one is by cellular modem and a sim card with data package (at least 100Mb), and the second one is by connecting to the local Wi-Fi net.

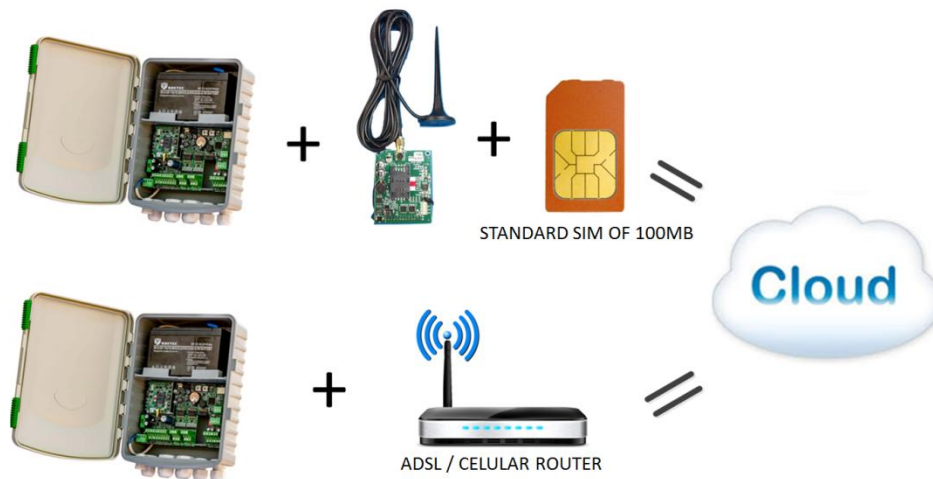

4.2 Cellular modem

To connect the controller to TALGIL's server, disconnect it from the power supply and rechargeable battery, open carefully the SIM card holder place it in the right position, and close the holder, to continue, go to paragraph 6.

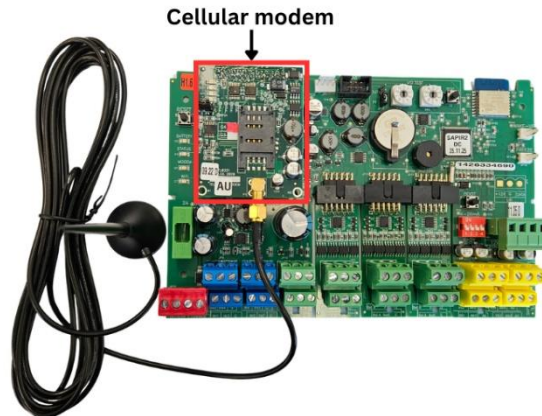

4.3 WI-FI

The Wi-fi modem connection will be ready in Q2 of 2020.

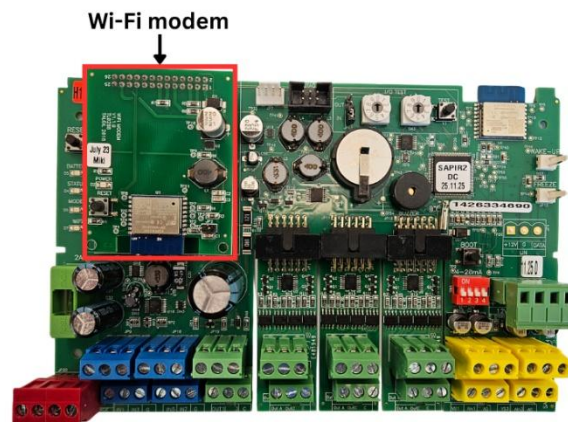

5. Communication with the controller

Communication with the controller is made by using 2 platforms, the first platform is the **DREAM CONSOLE PC** software (computers, laptops), and the second one is the **SPOT** app (smartphone, tablet).

5.1 Available internet connection

When there is a solid internet connection both options (**CONSOLE** and **SPOT**) are available, the installer **MUST** connect the controller to the internet to create the system configuration.

5.2 No internet connection

In case of no internet connection, only the **SPOT** app is available and will work only while the user is standing near the controller and the internal WIFI component is turned on.

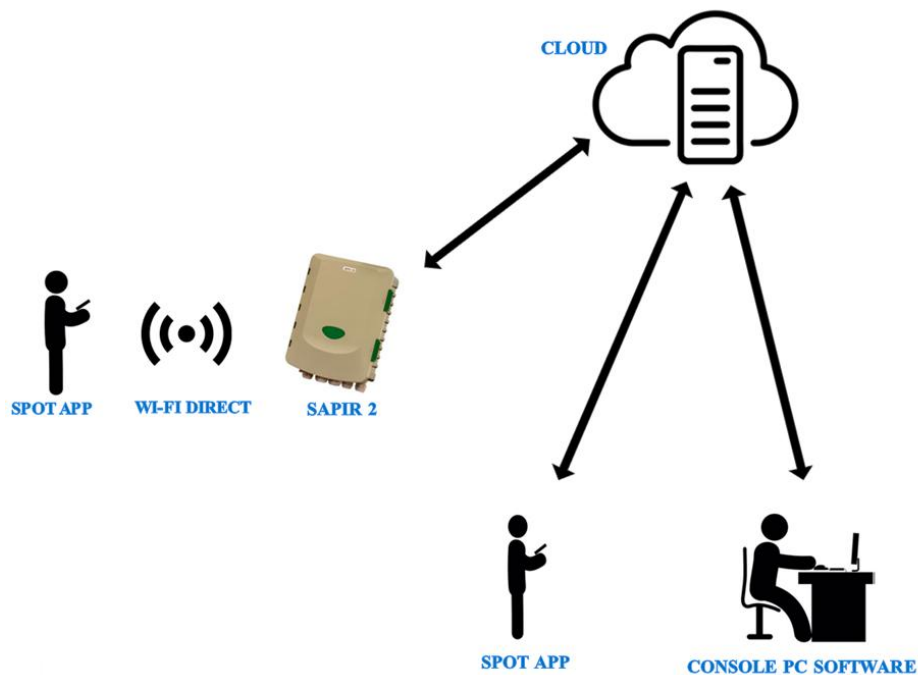

Note – there is no physical connection between the controller and the computer

Indication of LED's status

A. Battery LED status:

1. **Off:**
 - I. **Dead battery.**
 - II. **There is no power source connected.**
2. **Blinking:**
 - I. **Slow** – normal operation, without battery charging.
 - II. **Long + 2 shorts** – Low battery.
 - III. **Fast** – Battery charging problem.
3. **On** - Normal operation, with battery charging.

B. Status:

1. **Off** - Not active.
2. **Blinking** – Slow, normal operation.

C. Modem:

1. **Off** – Not active / connected.
2. **Blinking** – connecting.
3. **On** – connected.

D. Wi-Fi:

1. **Off** – Not active.
2. **Blinking** – Wi-Fi is active.

LED'S LOCATION ON THE SAPIR2 BOARD

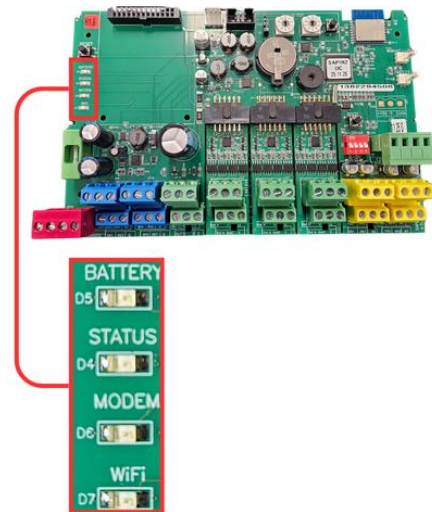

6. First introduction and downloading

6.1 What is SPOT?

The DREAM SPOT application is a platform that allows programming and monitoring the SAPIR 2 from the user's smartphone or tablet,

The App allows the user to create and edit irrigation programs, monitor irrigation performance, analysis of inputs (sensors water meters...), detailed event logs, and much more.....

6.2 Downloading from the Android operating system

1. Enter the “Play Store” App.
2. Write on the search bar – dream spot
3. Download the App.



6.3 Downloading from the IOS operating system

1. Enter the “App Store”.
2. Write on the search bar – dream spot.
3. Download the App.

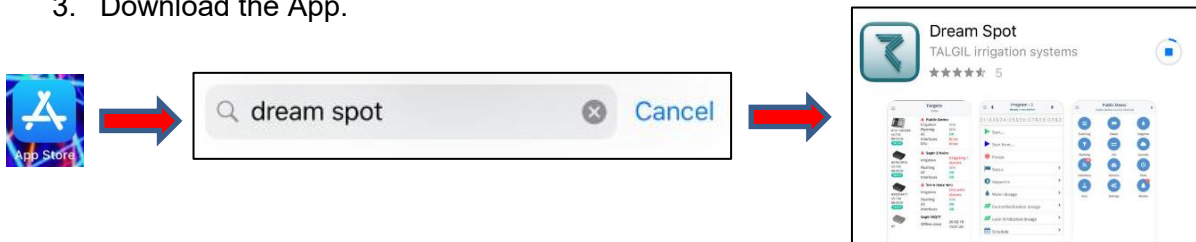

7. Connecting to the SAPIR2

8.1 Connecting with SPOT to the server (online)



Pointers and connection steps

1. Open the **SPOT** App on your smartphone.
2. Make sure you are on “**Talgil server**”, If not, tap on the select server box and select from the list (**pointer A**).
Talgil server – internet connection
Wi-Fi Direct – connection by local Wi-Fi, **no internet connection**.
3. Insert your username and password.
4. If you want to stay connected with the inserted user name and password mark “**Keep me logged in**”.
5. Sign in.
6. Tap In case you forgot your password.

8.2 Connecting with SPOT to the SAPIR2 (Wi-Fi Direct)

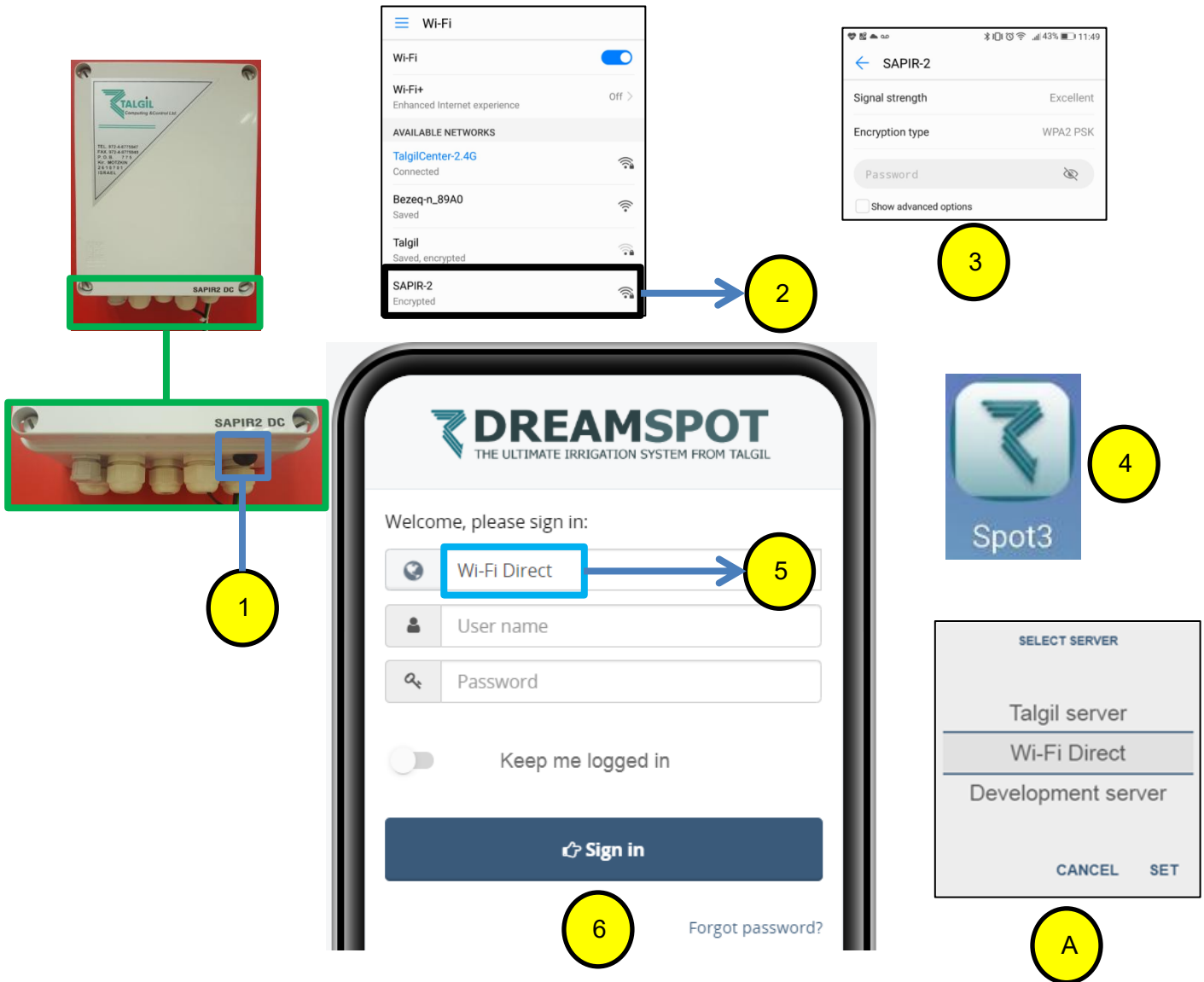

Pointers and connection steps

1. Press on the WiFi activation button.
2. Go to "Settings / WiFi Connections" on your smartphone and select "SAPIR-2".
3. Enter the following password: 12345678 and "Connect".
4. Open the SPOT App.
5. Make sure you are on "Wi-Fi direct", If not tap on the box and select from the list (pointer A).
6. Sign in.

8. Selecting controller from the list (in case you have more than one)

The screenshot shows the 'Controladores' app interface for the 'olivos' project. The top navigation bar includes a hamburger menu icon (labeled 1) and a filter bar with icons for project, disconnected, irrigation, flushing, interface, RTU, battery, and AC (labeled 2). The main content area displays a list of three controllers:









Controller Name	Model	Version	Time	Voltage	Status
Riomau	#83281617	v0.180	07:47:38	12.5 V	Inactivo OK OK
San Julian	#1499574659	v4.106	07:47:27	13.9 V	Regando OK OK OK
San Manuel	#1366189303	v4.106	07:47:39	14.1 V	Inactivo con alarmas OK OK

A sidebar menu (labeled A) is visible on the left, containing 'My preferences', 'Send Feedback', and 'Log out'. Arrows point from labels 1, 2, 3, and 4 to specific UI elements: 1 to the hamburger menu, 2 to the filter bar, 3 to the 'Regando' status of San Julian, and 4 to the controller details of San Julian.

Pointers

1. Tapping on the 3 lines icon will open a list of options (**Pointer A**), explanation of these parameters can be found in **paragraph 7.1**.

2. Controllers list filters:

-  Filter by project.
-  Filter by disconnected controllers.
-  Filter by controllers with problems in irrigation programs.
-  Filter by controllers with flushing problems.
-  Filter by interface problems.
-  Filter by RTU problems.
-  Filter by battery problems.
-  Filter by AC problems.

3. A list of controllers shows general information such as the controller's ID, Version, time, battery Voltage, irrigation, etc.
4. To enter one of the controllers tap on its picture.

7.1 Controller options list

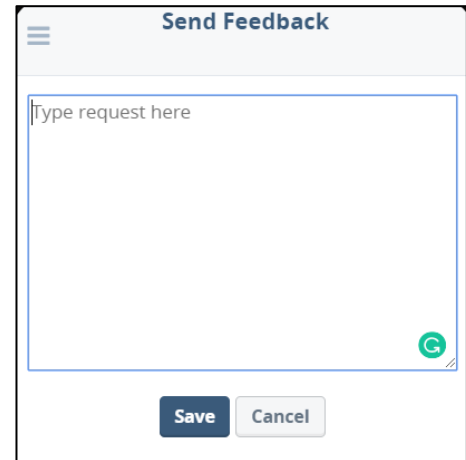
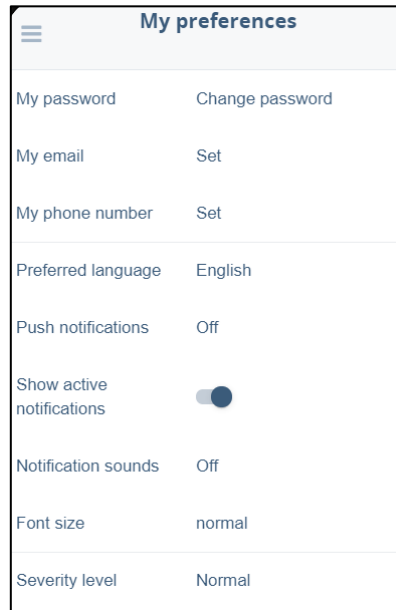
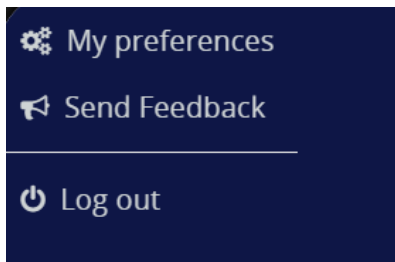

Pointers

1. **My preferences** - will open the My preferences parameter list, tap on the subject to get a short explanation, and to modify tap on the subject definition.
Send Feedback - this will open a window where you can write a message directly to TALGIL, and we will get back to you.
Log out - exit from the Application.

Push notification options:

Off—push notifications will not be sent to this user, he will receive only emails to the address as defined in **My email**).

Delayed – Push notifications will be sent to the user in bulk aggregate every 1 hour.

Faults only – Faults will be sent instantly as push notifications, other events are ignored.

Normal – Faults will be sent instantly; other events will be aggregated and sent every 5 minutes, and all the notification will be sent as push notifications.

Verbose – Everything is sent instantly (developers and affiliates only).

9. Home Page

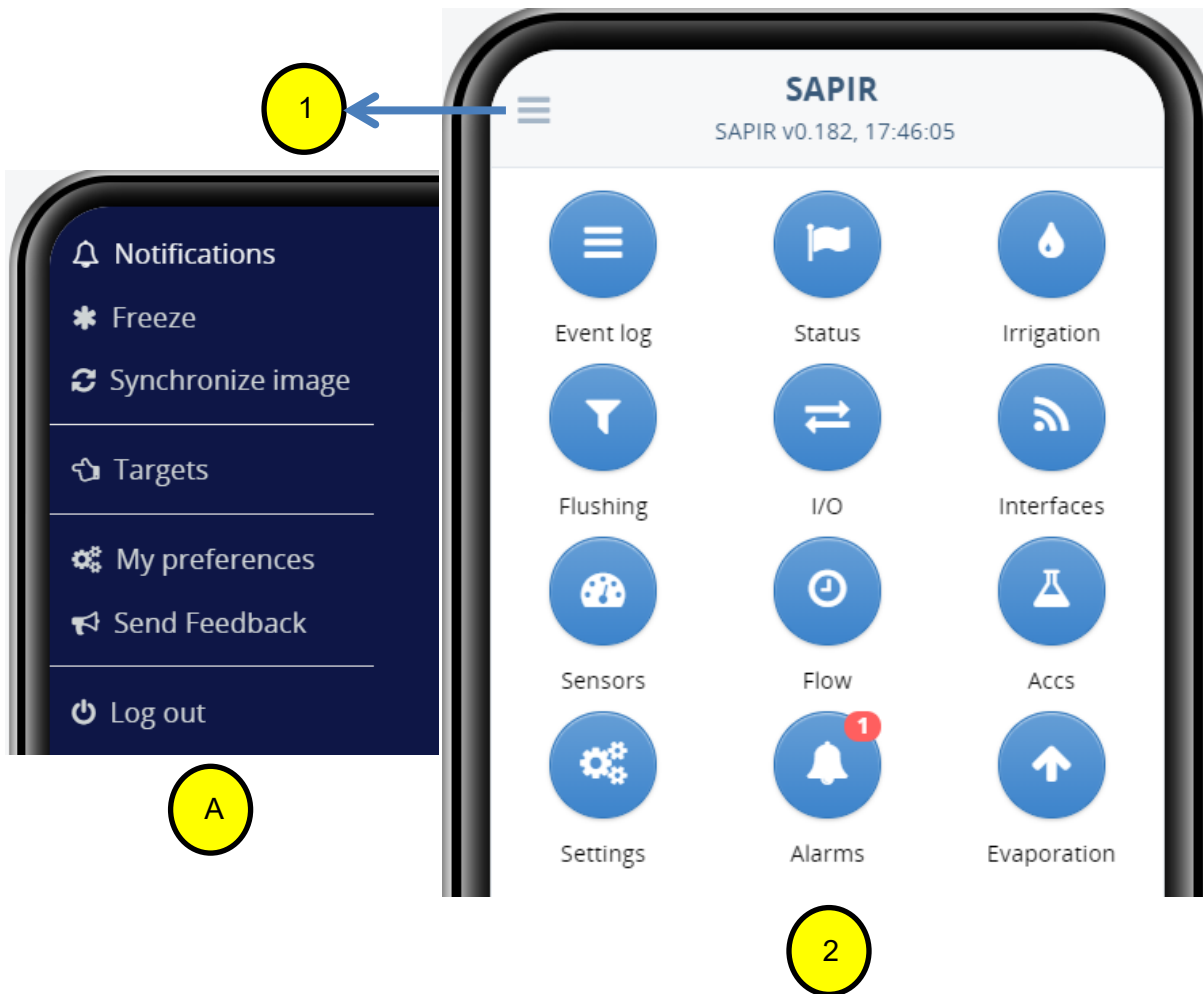

Pointers

1. Tapping on the 3 lines icon will open a list of options (**Pointer A**), an explanation of the list can find in **paragraph 8.1**.
2. The home page contains all the subjects covered by the **SPOT**, it is the place from where the user can reach all of those subjects.

Note - To move between screens you can scroll the screen from side to side, tapping on the header will take you to the previous screen.

10.1 Home page Option list

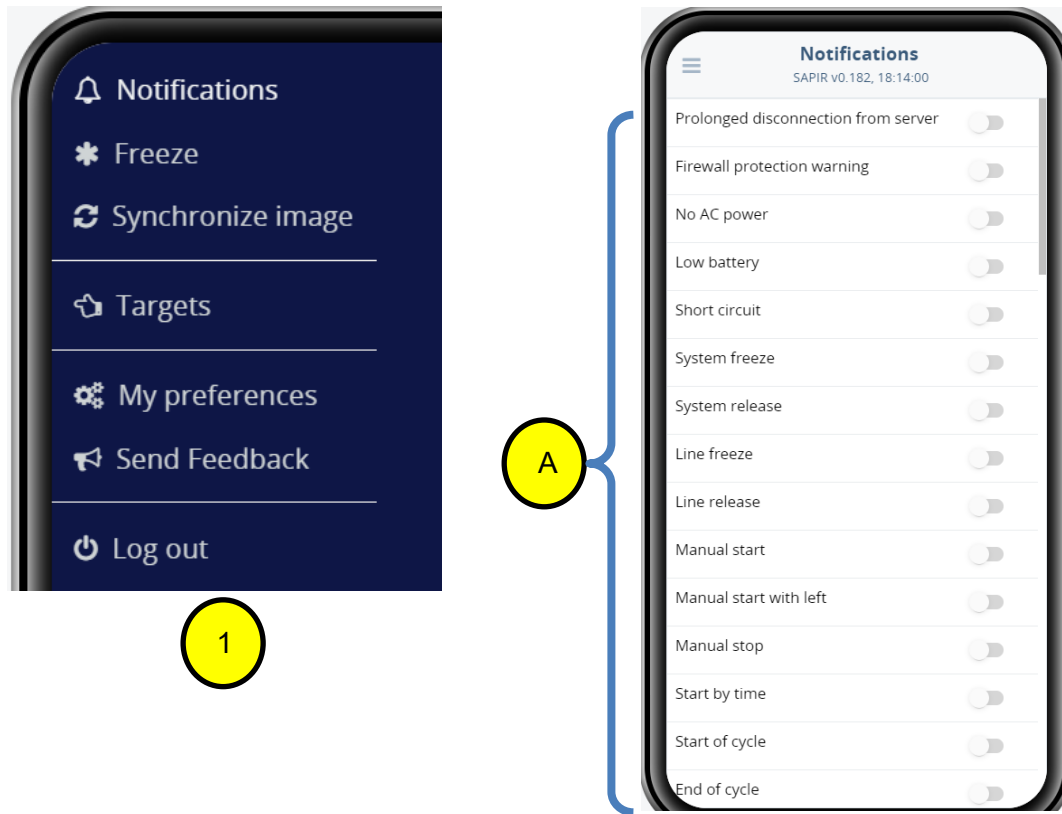

Pointers



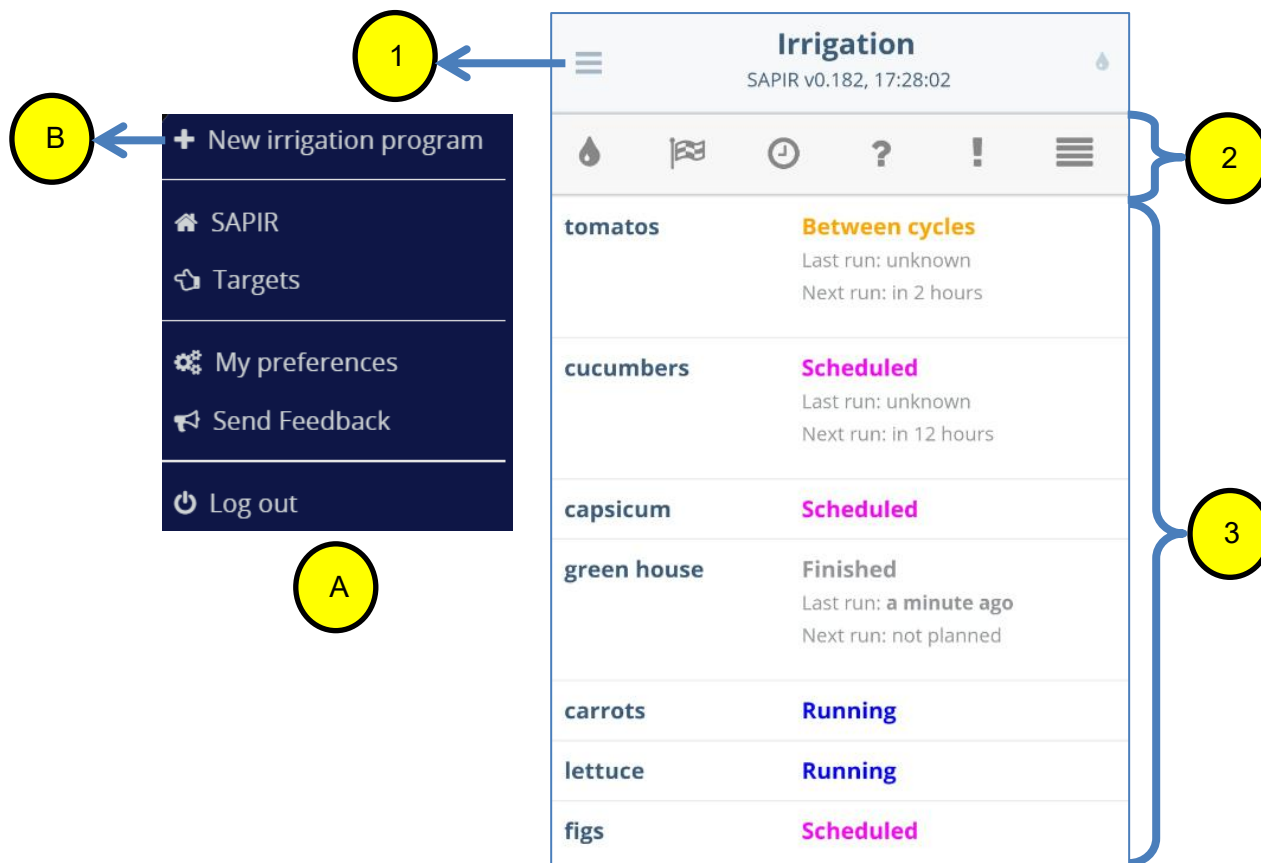

1. **Notifications** - will open the notifications list (**pointer A**), and mark the relevant notifications that you want to get by push notifications or by email (see paragraph 7.1 My preferences list).
Freeze - will pause the controller activities, tap on **Release** to unfreeze it.
Synchronize image - used for manual synchronization between the controller and the server.
Targets - will send you back to the controllers' list.
You can find information on the last 3 options in paragraph 7.1.

10. Irrigation

Irrigation



Pointers

1. Tapping on the 3 lines icon will open a list of options (**Pointer A**), and tap on **New irrigation program (Pointer B)** to create one (explanation of how to create a new program in paragraph 9.1).
2. The following icons are irrigation programs filters list and refer to:
 -  - Show running Irrigation programs.
 -  - Show finished irrigation programs.
 -  - Show scheduled and conditioned irrigation programs.
 -  - Show incomplete and not-ready irrigation programs.
 -  - Select an irrigation line (the SAPIR 2 has only one).
3. Irrigation programs list, the list will change according to the selected filters, tapping on one of the programs will take you to the program setup.

11.1 New irrigation program

To create a new irrigation program, tap on the 3 lines icon in the **Irrigation** screen, and select **New irrigation program**.

11.1.1 Sequence – select the valves or/ groups that will participate in the program, the symbols that first valve 1.2 will irrigate after it finished will start 1.3 after it G1 (Group 1) etc.

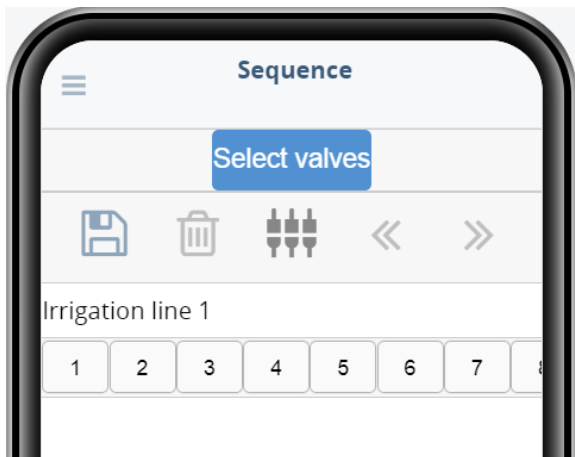

New irrigation program without valves

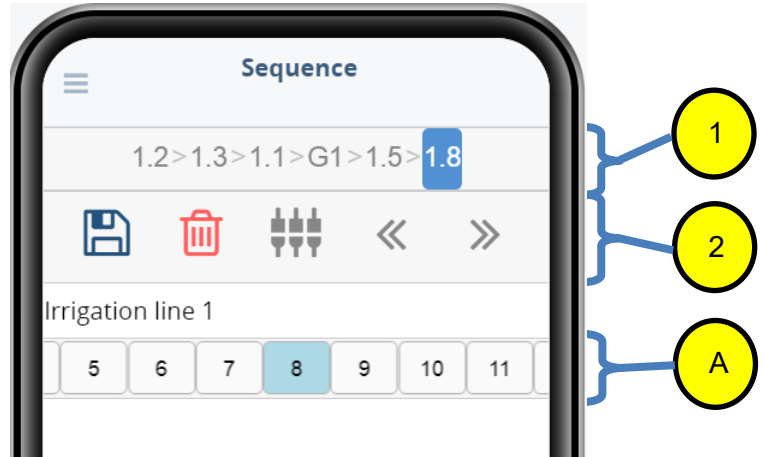

New irrigation program with valves



Pointers

1. Valves or groups that participate in the program, to add valves to the program tap on the valve number (**pointer A**).
2. The following icons are used for:
 -  - Save the irrigation program, tapping on the icon will open a window to name the irrigation program, and to complete the missing details of the program (see paragraph 9.1.2).
 -  - Delete valves/groups from the program.
 -  - Add a group of valves to the program.

11.1.2 Irrigation program – from the main screen of the irrigation program

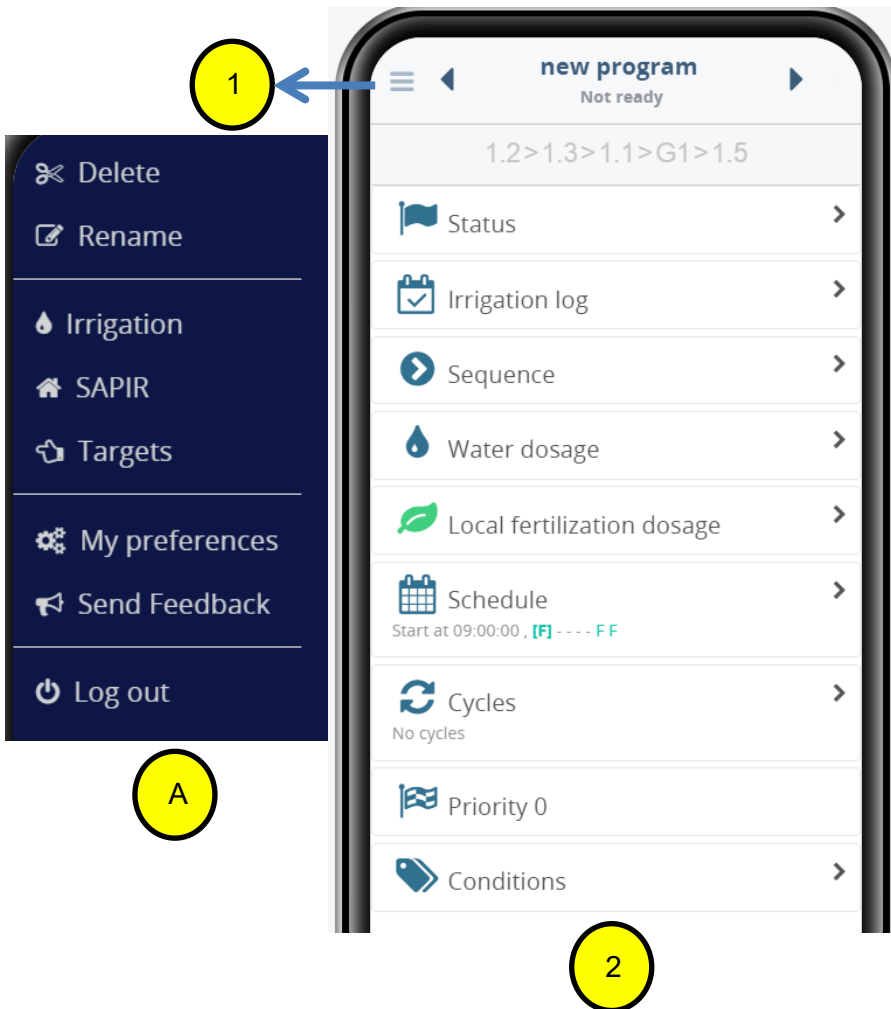

Pointers

1. Tapping on the 3 lines icon will open a list of options (**Pointer A**), in the list you can find options such as rename or delete program, going back to home page or irrigation screen, enter to my reference and log out.
2. Irrigation program parameters, tap on the subject you want to edit or view.

Note

- Explanation for **Local fertilization dosage** – is under Water dosage.
- Explanation for **Priority** – is under schedule.

Water dosage -

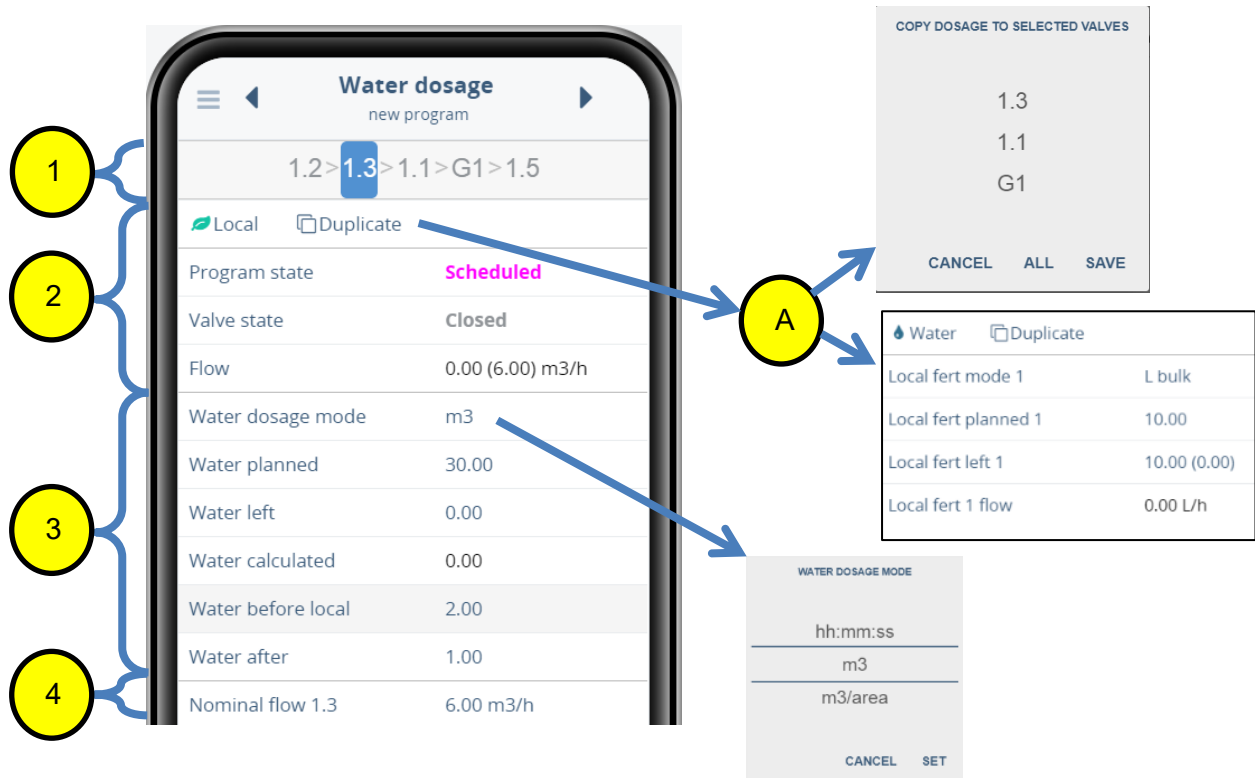

Pointers

1. Valves or groups that participating in the program, taping on each one will open the valve status and dosage options.
2. **Local** - will open the fertilization screen, to go back tap on “Water” (Pointer A).
Duplicate - is for copying the dosage to selected valves or groups (Pointer A).
Program state – status of the program, for example: Scheduled, scheduled today, not ready, irrigating and etc.
Valve state – Closed, Open and etc.
3. Water dosage planning, tap on the subject that you want to modify.
Water dosage mode – set the required dosage mode.
Water planned – insert the quantity / time of irrigation.
Water left – how much water is left to finish the program.
Water calculated – calculation of the whole amount of water for irrigation, being use when using dosage mode m3/area
Water before local – water before fertilization.
Water after – water after fertilization.
4. Set the valves nominal flow if needed.

Schedule -

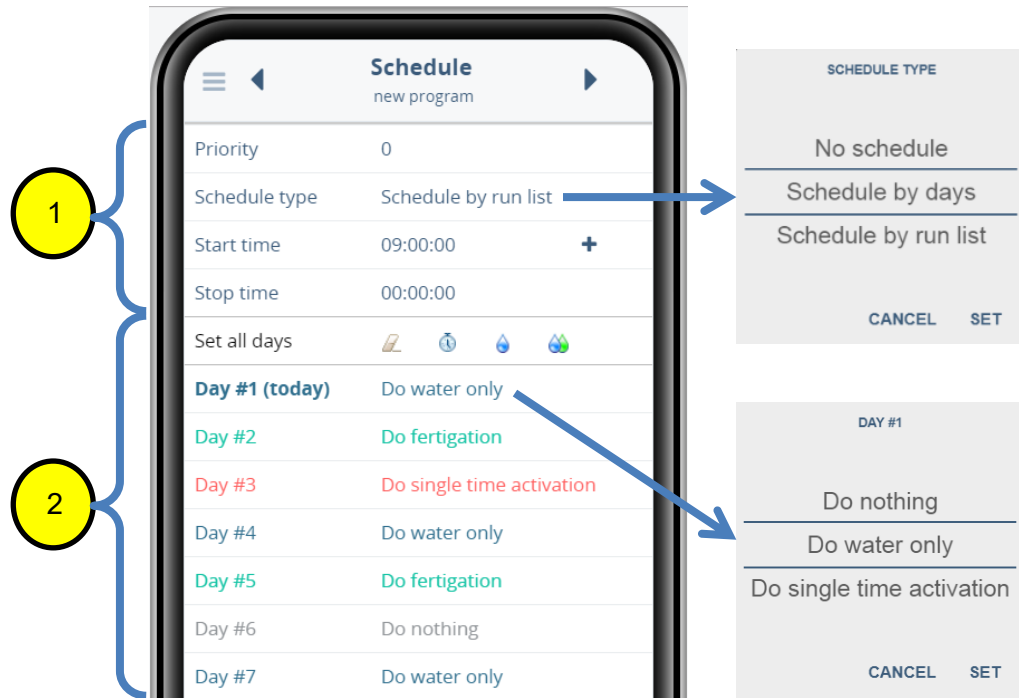

Pointers

- 1. Priority** – giving a higher priority to the program over other programs in case of conflict between them, 9 is the higher priority and 1 is the lowest.
For example, Conflict between programs can happen when irrigating 2 programs with different fertilization dosage in the same.
Schedule type – schedule the irrigation days by days or run list.
Start time – setting the program start time each program can have up to 6 start times.
Stop time – is used when it's needed to stop the program in a specific time.
- 2.** Set the type of activation for each day by tapping and selecting from the list, if you want to change the settings for all days use **set all days** option.

Cycles -

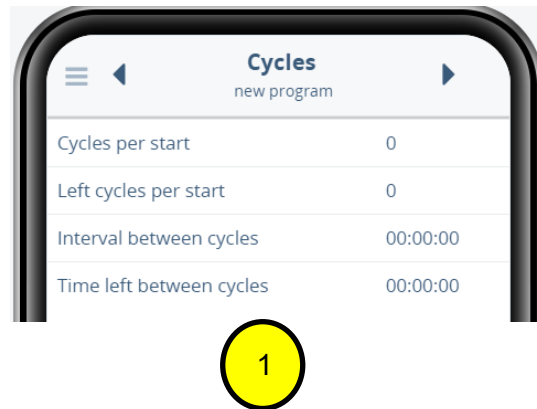

Pointers

1. **Cycles per start** – insert the repeated cycles quantity of the irrigation program.
2. **Left cycles per start** – how many cycles left.
3. **Interval between cycles** – time between cycles, the time setting is only between start time to start time.

Conditions – the conditions are being use in special cases when normal programming (start time and day, dosing by time / volume....) is not enough.

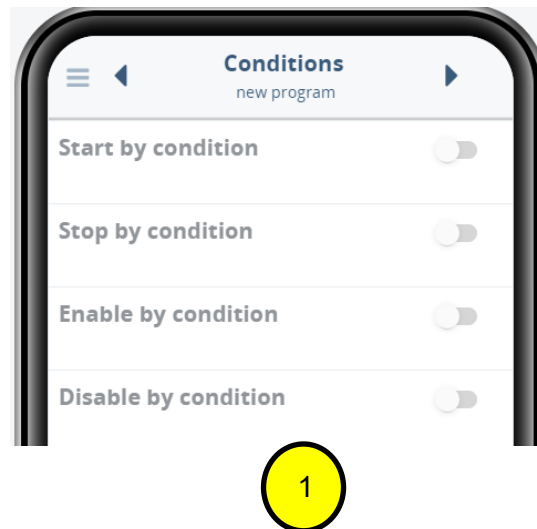

Pointers

1. **Start by condition** – start the program when the condition is active.
2. **Stop by condition** – stop the program when the condition is active.

- 3. Enable by condition** – give permission to run the program according to its schedule, when the condition is active.
- 4. Disable by condition** – deny the permission to run the program according to its schedule, when the condition is active.

Tap on the  icon of the required condition, and follow the steps:

Step A

Tap on **Select condition type** and choose the condition from the list



Step B

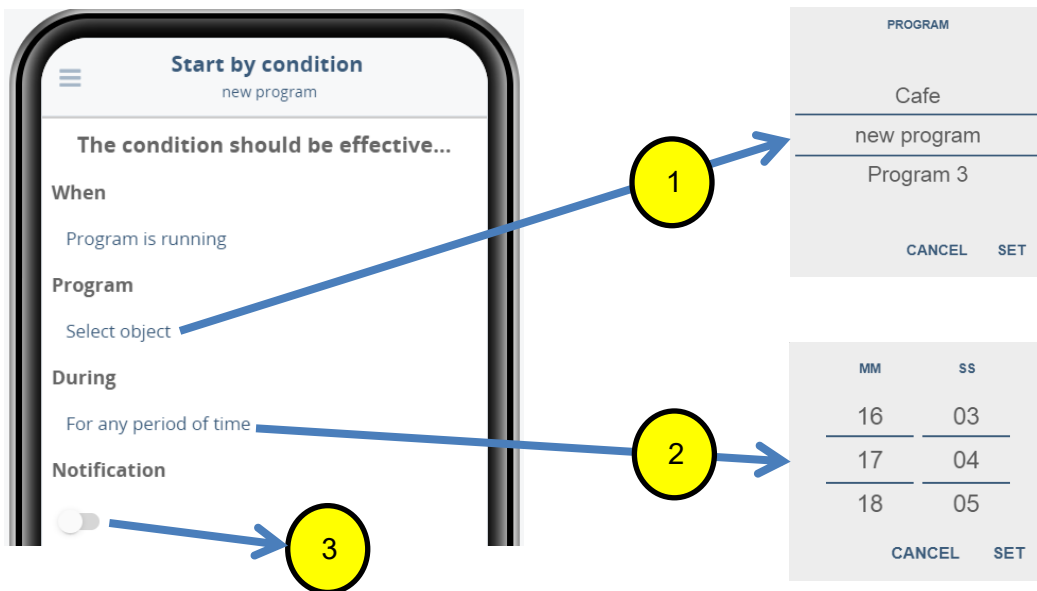

Pointers

- 1. Program** - Tap and select the relevant program from the list, when the condition will be "TRUE" it will start (for example) the selected program.
- 2. During** - Tap and set the period of time (delay) since the condition is "TRUE" until the program will start.
- 3. Notification** – mark to get messages when the condition takes place, make sure also to mark **Condition is active** in the **Notifications** screen (8.1 Home page Option list).

Status –

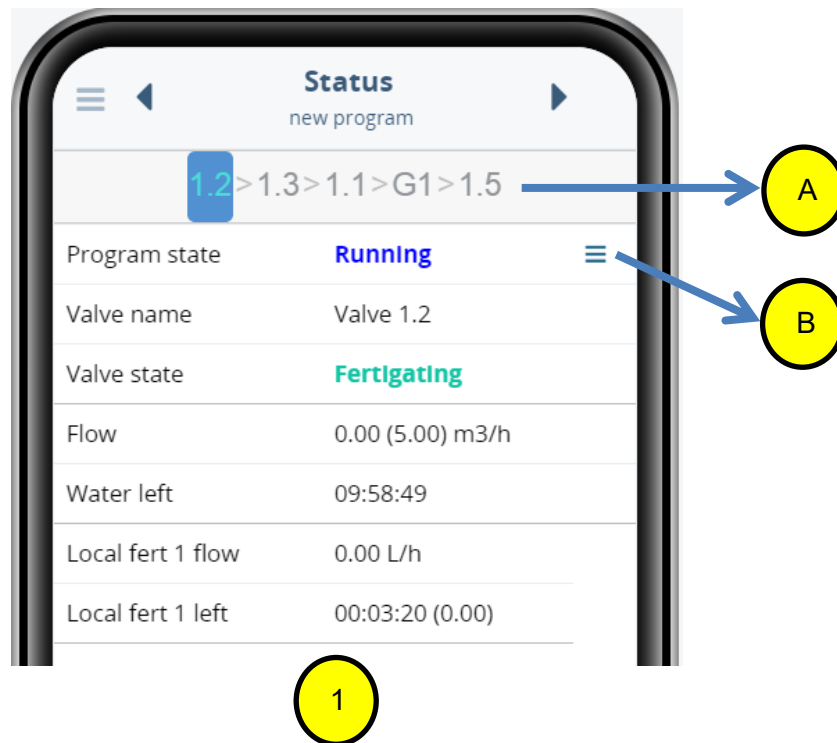

Pointers

1. Program status parameters:

Valves and/or groups sequence (**Pointer A**)

Program state – Status of the program and current valves / groups (Running, Scheduled and etc.).

Tapping on the ☰ icon will open the **Event log** screen.

Valve state – Irrigating, Fertigating, closed and etc.

Flow :

0.00 - Current flow.

(5.00) - nominal flow.

Water left – remaining time / quantity for finishing the program.

Local fert flow – current flow of fertilizer injector No. 1.

Local fert left - remaining time / quantity for finishing the fertilizers program.

Start, Start from, Freeze –

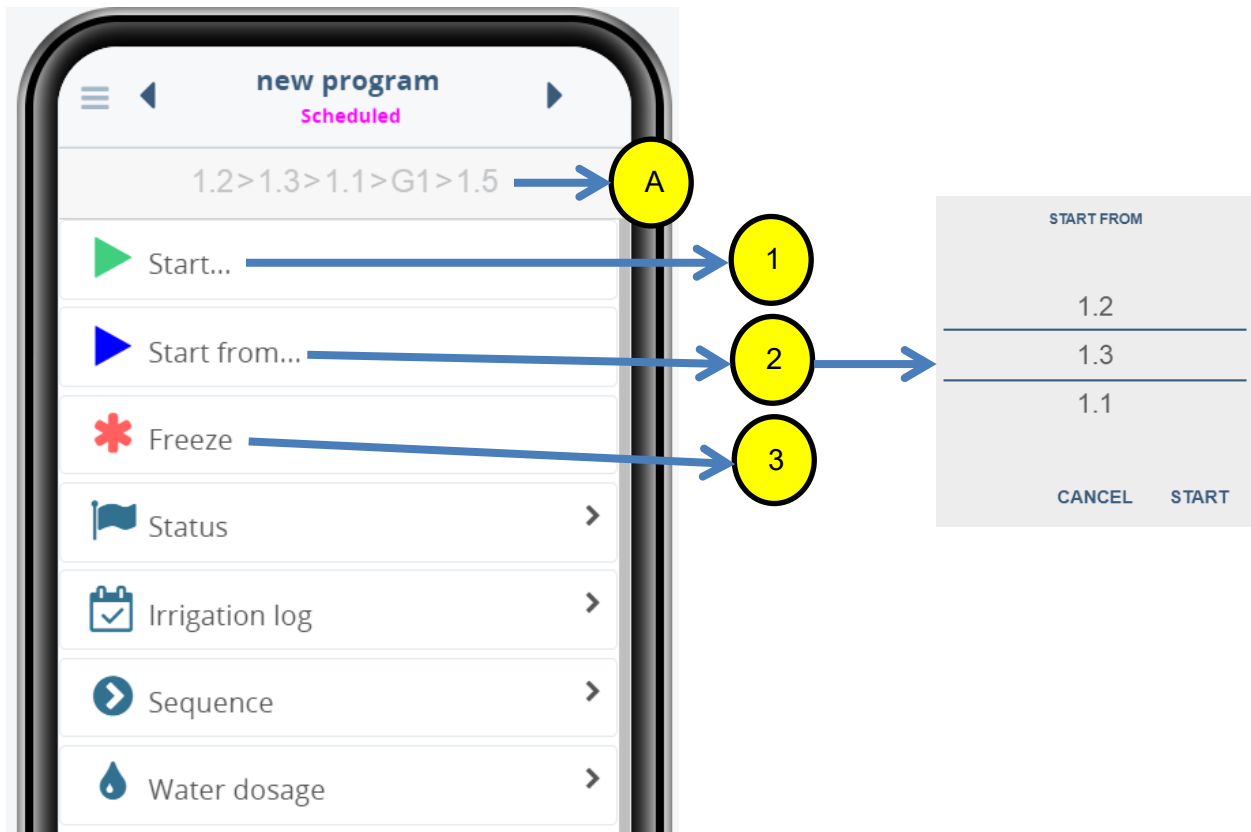

Pointers

1. **Start** – manual activation of the program.
2. **Start from** – start the program from another valve / group, for example, if we'll choose to start the program from valve 1.3 it will irrigate only 1.3,1.1, G1 and 1.5 (**Pointer A**).
3. **Freeze** – Pausing the program.

Irrigation log

An irrigation log is a tool that helps to Monitor, Analysis, and Tracking Irrigation programs. In addition, the Irrigation log displays the Planned in comparison to the Actual irrigation performances.

To display the Irrigation log of a specific irrigation program, navigate to the Irrigation screen. In the Irrigation screen, select the Irrigation program that you would like to display the Irrigation log.

In the Irrigation program screen, you will see the Program Name and Program status (**Pointer 1**).

Tap on the Irrigation log button (**2**). A calendar will appear on the top of the screen (**3**). On the Calendar, the current day is shown in dark blue color (**4**).

To see details on a specific date, select a date from the Calendar screen and tap the day (**4**).

As a result, details of the Irrigation on this day will appear on the screen (**5**). The details are: Cycle's number, Start time, Stop time, Total water and fertilization consumption by volume or by time.

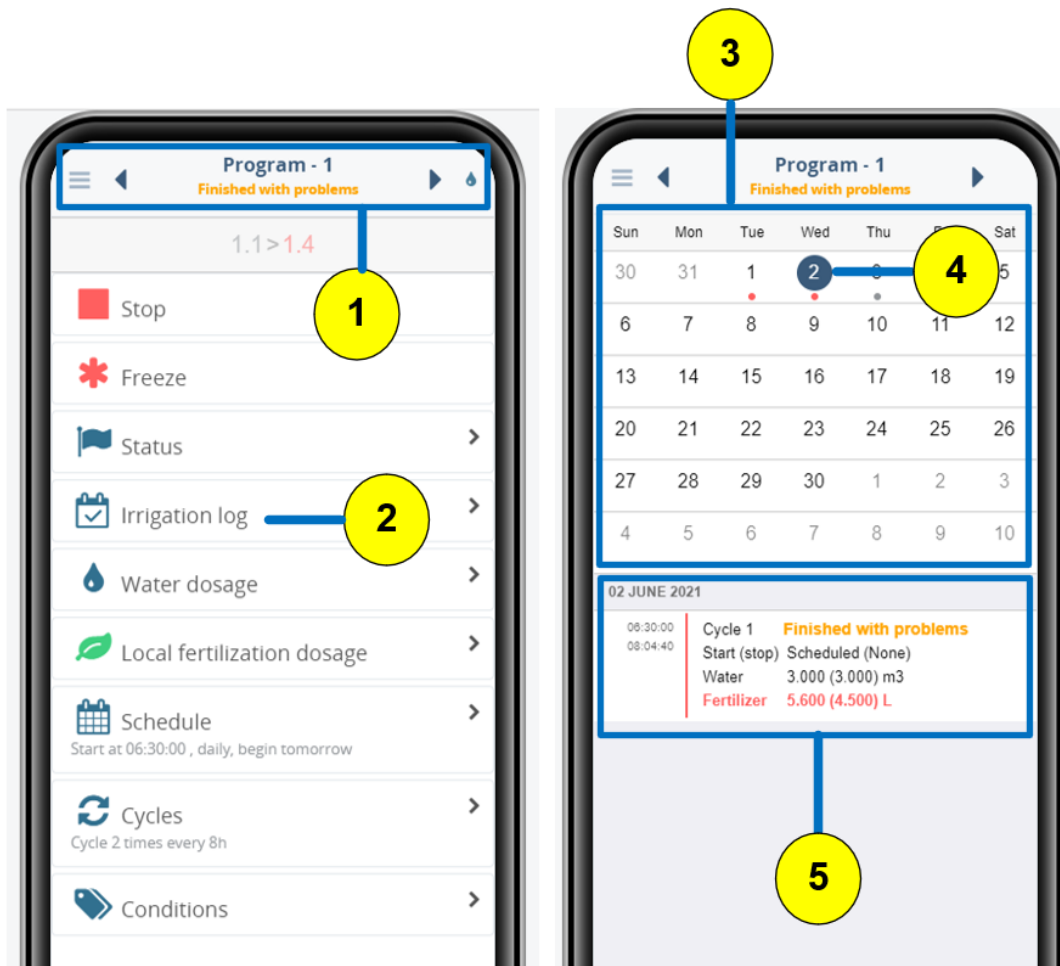

To compare between the planned and actual irrigation performance, tap the details under the Calendar (5). As a result, more details will appear on the screen. Select an irrigation valve (6) to display the relevant irrigation log for the irrigation valve.

The irrigation log data are:

8. Program state.

9. Program planned start time. The actual start time appears in parentheses.

10. Estimated Stop time. The actual stop time appears in parentheses.

11. Planned water dosage. The actual water dosage appears in parentheses.

12. Nominal flow. The actual water flow appears in parentheses.

13. Planned fertilization dosage. The actual fertilization dosage appears in parentheses.

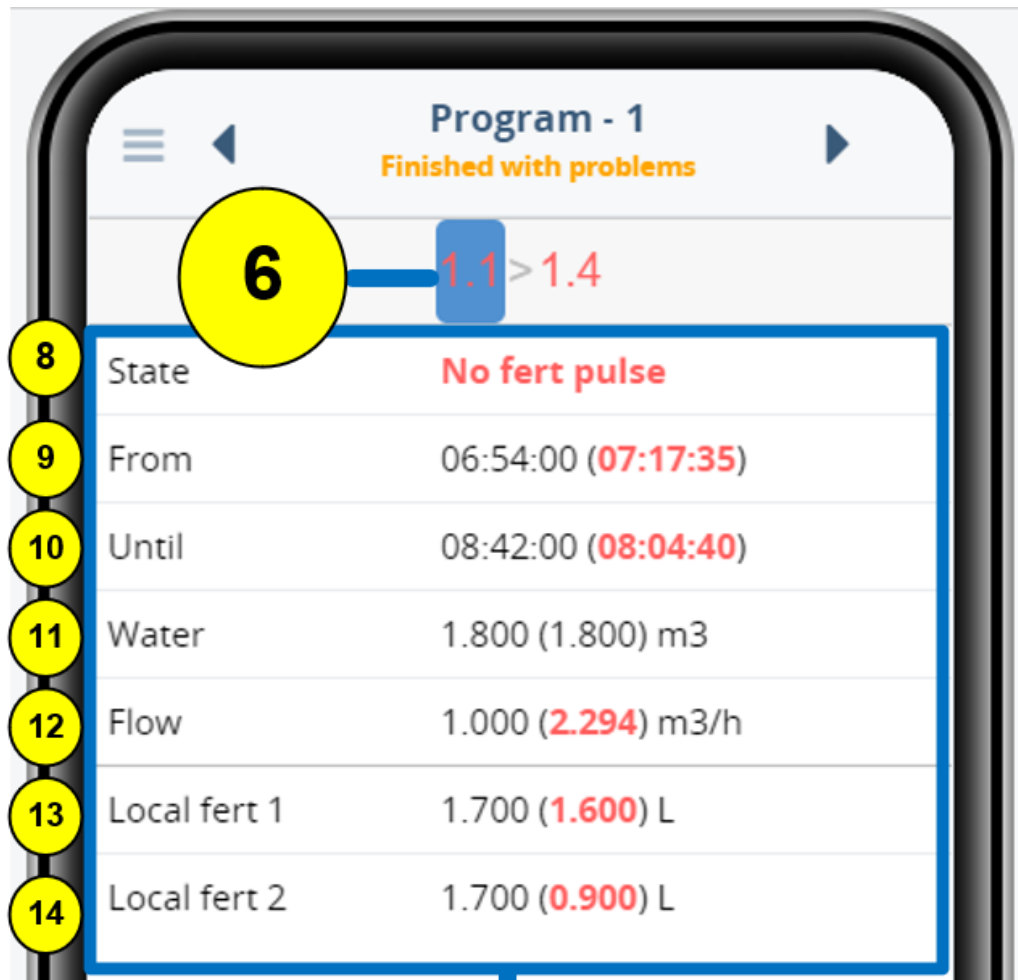

There
small

are
dots

under the dates. The dots indicate the Program states. The dot's color and Program state described below:

Dot Color	Program state
Gray ●	Scheduled to run in the future
Blue ●	Program finished (Water only)
Green ●	Program finished (Water + Fertilization)
Red ●	Program finished with problems
No color	No irrigation on this day

Screenshot 1-Blue Dot

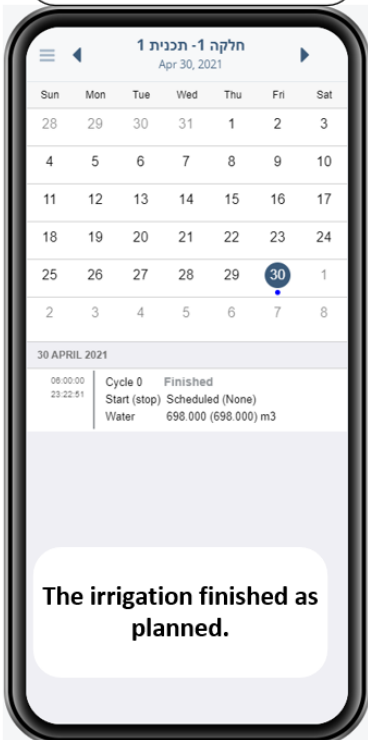

The irrigation finished as planned.

Screenshot 2 -Green Dot

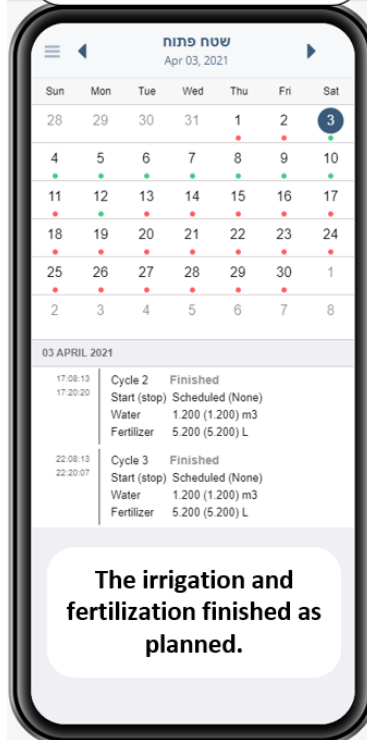

The irrigation and fertilization finished as planned.

Screenshot 3 -Red Dot

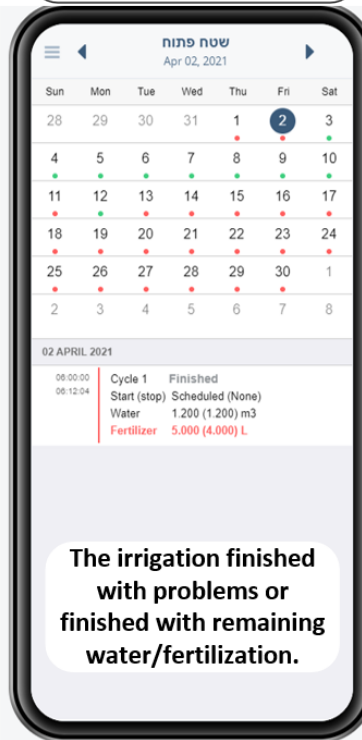

The irrigation finished with problems or finished with remaining water/fertilization.

Screenshot 4 -Gray Dot

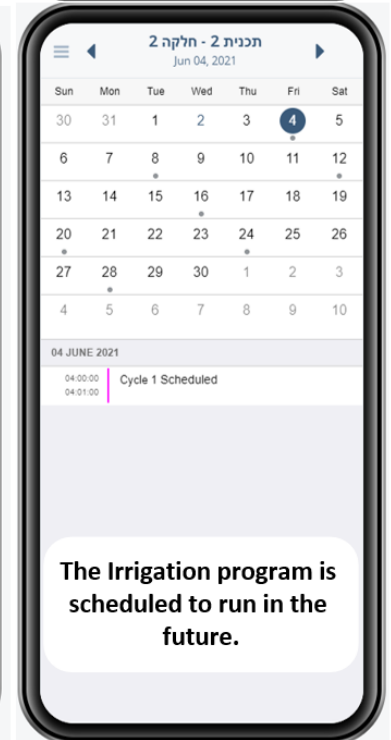

The Irrigation program is scheduled to run in the future.

11. Status

Status

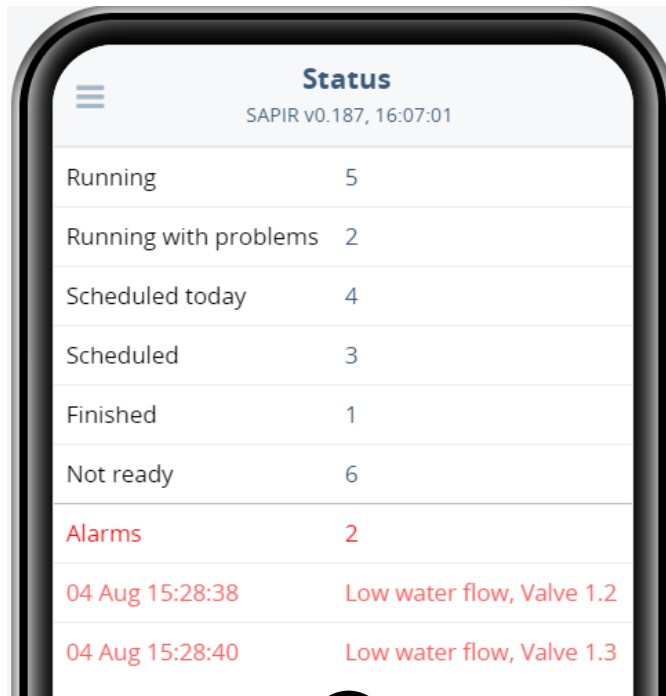

Status	
SAPIR v0.187, 16:07:01	
Running	5
Running with problems	2
Scheduled today	4
Scheduled	3
Finished	1
Not ready	6
Alarms	2
04 Aug 15:28:38	Low water flow, Valve 1.2
04 Aug 15:28:40	Low water flow, Valve 1.3

1

Pointers

1. **Running** – currently running programs.
Running with problems – currently running programs with a problem.
Scheduled today – programs that are scheduled to run today.
Scheduled – scheduled programs for another day.
Finished – Finished programs.
Not ready – programs with missing parameter (can be start time, water dosage...).

Note – the numbers are referring to the program number and not to the quantity of programs.

Alarms – Alarms events, for example in this case there are 2 alarms, and the details on each one of them.

12. Event log

Event log



Pointers

1. event log filters:
 - A. Search system events
 - B. Set the search start and end time of system events.
 - C. Show only alarms.
 - D. Show sanded events.
2. System events list.

14. Interfaces

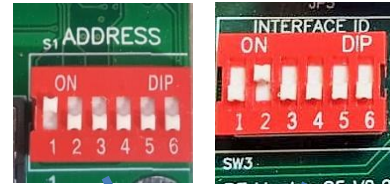
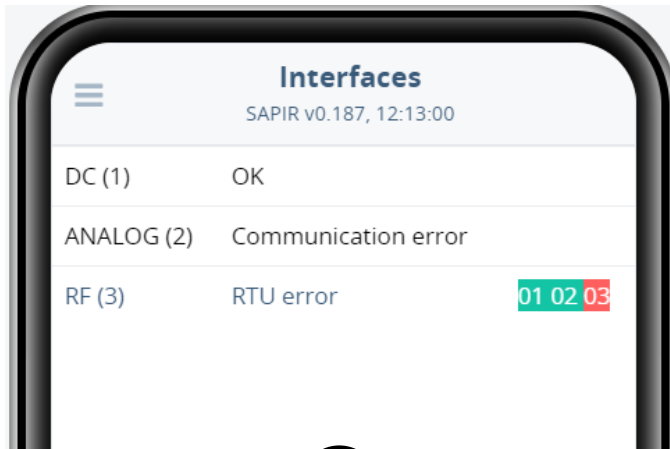

Pointers

1. The interfaces screen presents the interfaces that are defined in the system, the number in parentheses is the interface **ADDRESS / INTERFACE ID** number, and it should be defined in the same way as in the **ADDRESS / INTERFACE ID** Dipswitches on the interface board (**Pointer A**).

Communication error – there is no communication with the interface.

RTU error – there is no communication with the RTU's marked in red.

15. I/O (Inputs / Outputs)



I/O



Pointers

1. **Outputs** -Tapping on each one of the parameters will open a list with the assigned outputs, there you will be able to see the output status (Opened by program, Close, Low flow and etc.) and Open or Close outputs manually.
2. **Inputs** - Tapping on each one of the parameters will open a list with the assigned inputs, there you will be able to see the input status (Close, Open, Flow, No flow and etc.).

16. Flushing

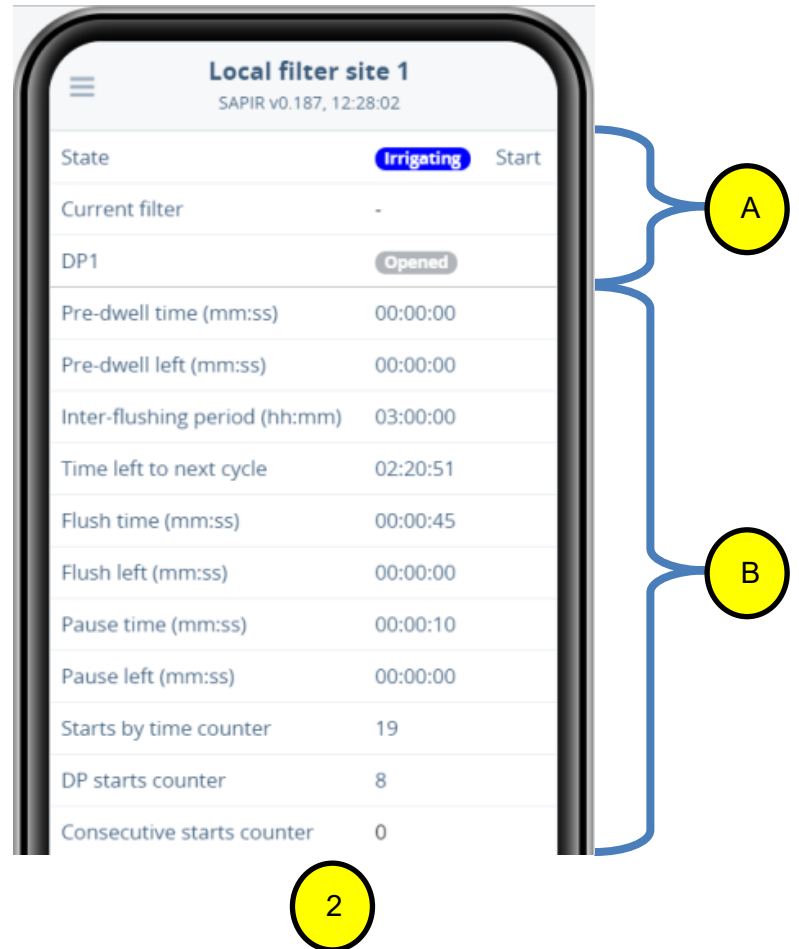
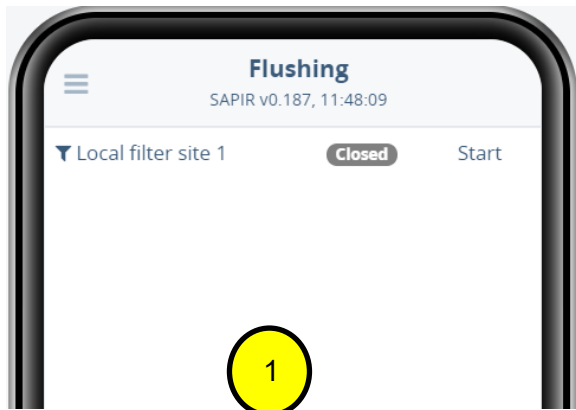

Pointers

- The flushing screen demonstrate the Local filter site status (closed, Flushing, irrigating), to edit the filter site parameters tap on **Local filter site 1**, to start manual flushing sequences tap on **Start**.
- Edit screen of the filter site:
 - State** – Filter site status and manual activation.
Current filter – the current flushing filter in the sequences.
DP1 – Opened: there is no differential pressure.
Closed: there is differential pressure.
 - Inter-flushing period (hh:mm)** – set the time between flushing cycles.
Time left to next cycle – the countdown to the next cycles will run only while there is an irrigation program/s running.
Flush time (mm:ss) – back flushing time of each filter (one time setting for all the filters, in this case, all filters will flush 45 seconds, one at a time)
Flush left (mm:ss) – time remaining of the current flushing filter.
Pause time (mm:ss) – waiting time between filters flushing.
Pause left (mm:ss) – time remaining for the next filter in the flushing sequence.
Starts by time – how many flushing cycles were activated by time.

DP starts counter - how many flushing cycles were activated by DP.
Consecutive starts counter - The number of consecutive cycles by DP considered as endless looping alarm.

17. Accs (accumulations)



Accs

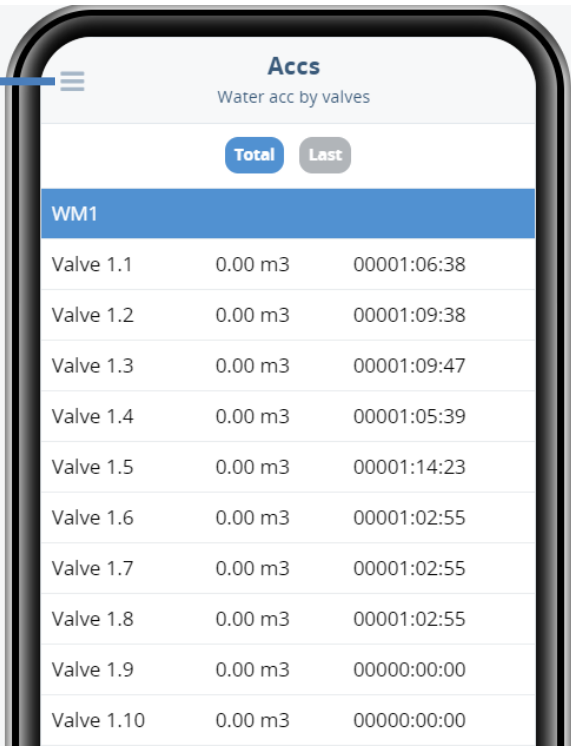
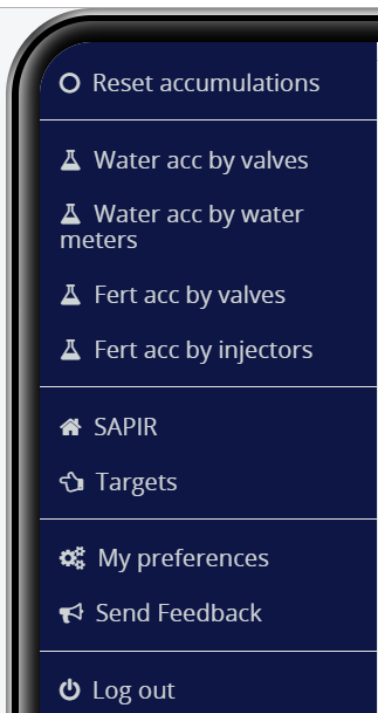

Pointers

- 1. Water accumulation of each valve, can be filtered to Total accumulation of the valves or Last (accumulation of the last irrigation).
- 2. Tapping on the 3 lines icon will open more accumulation options - Reset accumulations and Water and fertilizer accumulations by valves and meters.

18. Flow

Flow

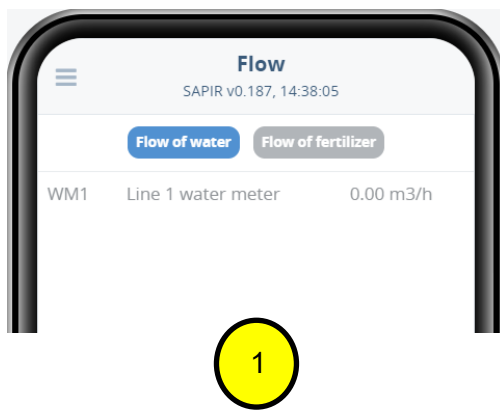

Pointers

1. Water meter flow.
2. Fertilizer meters flow.

19. Sensors

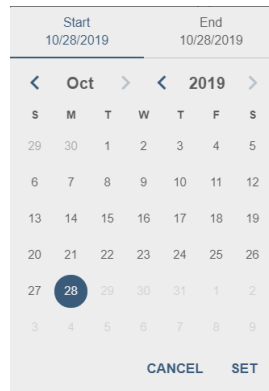
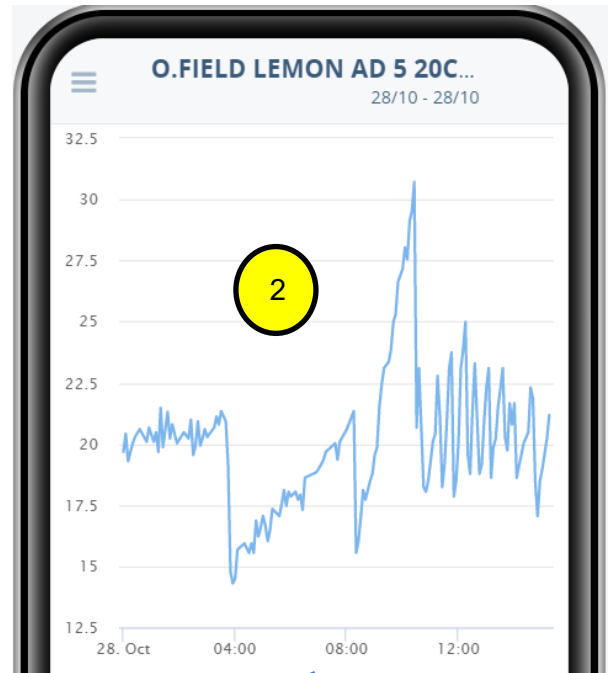
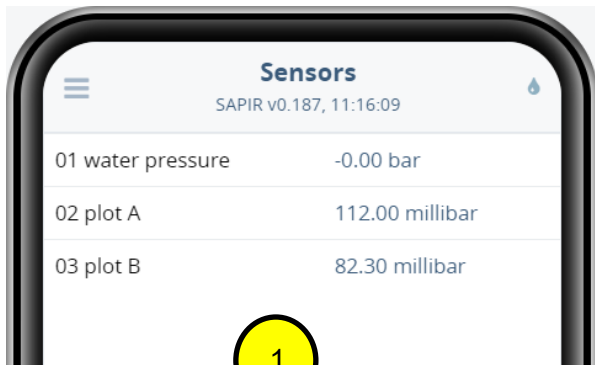

Pointers

1. Current sensors values.
2. Tapping on each sensor will open its graphical history, to change the time line tap on the dates, this operation will open a calendar (**Pointer A**) to set the start and end time.

20. Evaporation



Pointers

1. The system saves the Evaporation data (from the weather station or inserted manually) during 16 days, every day it's adding yesterday's evaporation and deleting the 17's day. To insert or modify the daily Evaporation just tap on the values.
2. To set a program to irrigate according to Evaporation:
 - A. go to Irrigation
 - B. select or make a new program.
 - C. Water dose.
 - D. select evapo (m3) or evapo (time)
 - E. set the day interval and time to start.

PLEASE NOTE – if the program interval is every day it will calculate and irrigate according to yesterday's Evaporation values, if the irrigation is every 2 days it will calculate and irrigate according to the last 2 days Evaporation and etc.

21. Alarms

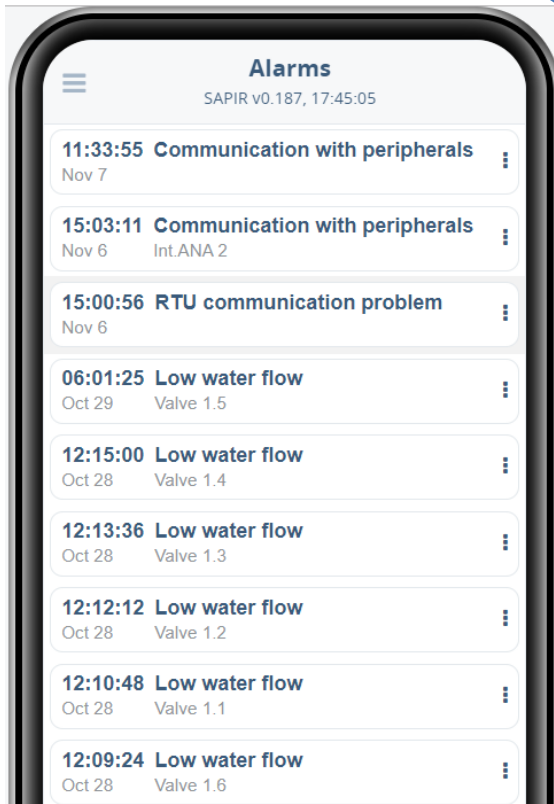

Pointers

1. The number (red circle with white number) on the Alarms icon refers to the number of standing alarms of the system.
2. List of the system standing alarms, to clear alarms tap on the 3 dots icon of selected alarm, and select between **Clear** this specific alarm or clear **This type** which will clear all similar alarms (**Pointer A**).

22. Settings



Settings

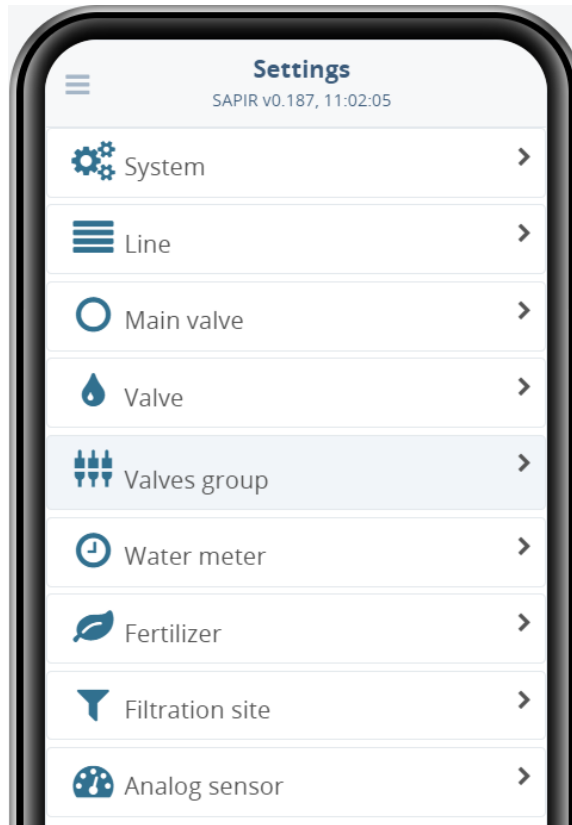

Pointers

1. The Settings screen uses for editing parameters regarding to each topic, in the following pages you can find explanation on each topic.

22.1 System

The system Settings is divided to 5 parts: Features, Default, Irrigation, Fertilization and Misc. below you can find explanation on each parameter of the list. Taping on each parameter will open a window with explanation on the parameter.

Features

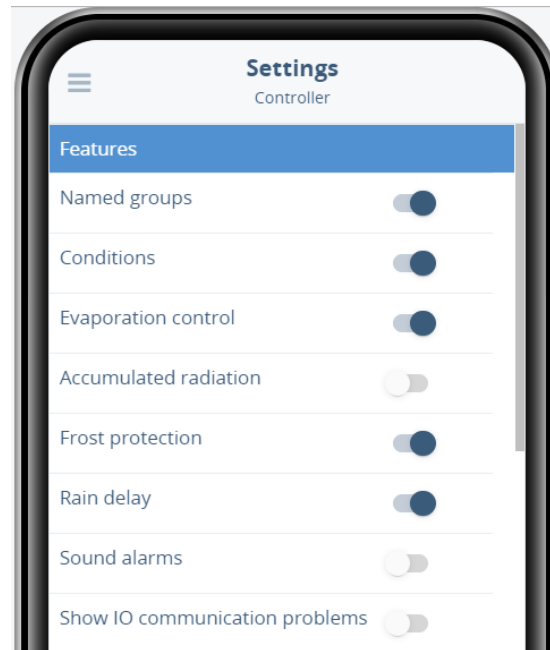

Named groups – Allow using named groups like G1,G2,G3 stored in groups library.

Conditions – permit using conditions.

Evaporation control – Water dosing by evaporation using crop factor.

Accumulated radiation – permit triggering the cycles of irrigation by accumulated radiation.

Frost protection – permit using the frost protection mechanism.

Rain delay – permit using the rain delay mechanism.

Sound Alarm – Not in use.

Show IO communication problems – show communication problems in status of inputs and outputs.

Default

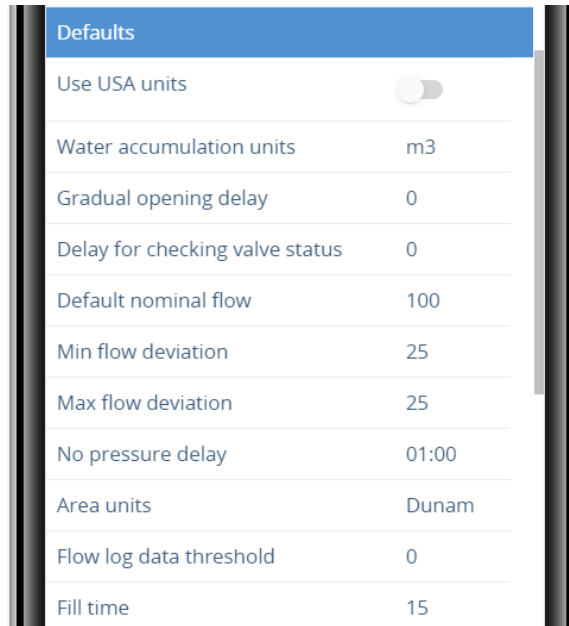

Defaults	
Use USA units	<input type="checkbox"/>
Water accumulation units	m3
Gradual opening delay	0
Delay for checking valve status	0
Default nominal flow	100
Min flow deviation	25
Max flow deviation	25
No pressure delay	01:00
Area units	Dunam
Flow log data threshold	0
Fill time	15

Use USA units – for using gallons, thg, inches and other American standard units.

Water accumulation units – when USA units were selected the accumulation can be by thg, acre-feet or acre-inch.

Gradual opening delay – When irrigating groups of valves, the opening/closing will be gradual with a delay between the valves.

Delay for checking valve status – Not in use.

Default nominal flow – Default nominal flow for all the valves.

Min flow deviation – Min flow deviation from nominal for all the valves (%).

Max flow deviation – Max flow deviation from nominal for all the valves (%).

No pressure delay – Delay before a change in a pressure sensor comes into effect (mm:ss).

Area units – Default dosage mode for all valves in the system.

Flow log data threshold – Flow data will be collected only when value fluctuates more than specified in percentages.

Fill time – Fill time in minutes for all the valves, in this period of time the controller is ignoring flow problems in all the valves.

Irrigation



Cycles – Enable repeating irrigation by cycles.

Priority – Enable prioritizing irrigation programs in case of conflict, the program with the higher priority will irrigate and the other will wait. Higher number indicates higher priority.

Dosage per area – Dosing the water by volume/area using crop factor of each valve.

Default dosage mode – Default dosage mode for all valves in the system.

Stop time => max duration – Not in use.

Halt on repeated flow problems – Not in use.

Enable long sequence – Not in use.

Reuse valve in sequence – Allow using the same valve in program sequence.

Parallel program in line – Allow using parallel programs in the same sequence.

DP control during line filling – Allow DP control during line fill delay.

Run list length – Length of irrigation days list.

Current irrigation day – Current irrigation day in the Run list of irrigation days.

Common dosage coefficient – Not in use.

Reset time – When set to an none zero value, will stop all active programs when the specified time arrives. Value in minutes since midnight (hh:mm).

Fertilization

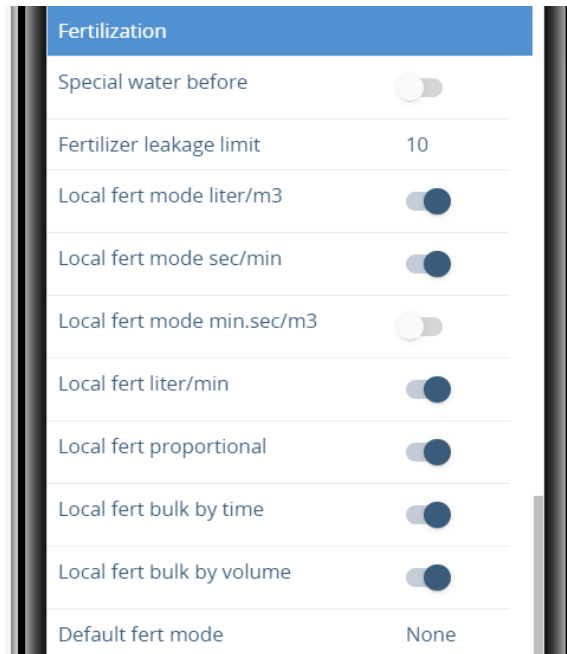

Special water before – Not in use.

Fertilizer leakage limit – Number of fertmeter pulses per 30 min to be considered as fertilizers leakage.

Local fert mode liter/m3 – Enable or disable fertilization mode where local fertilizer is supplied per volume of water.

Local fert mode sec/min – Enable or disable fertilization mode where local fertilizer is supplied by seconds every minute.

Local fert mode min.sec/m3 – Enable or disable fertilization mode where local fertilizer is supplied by time per volume.

Local fert liter/min – Enable or disable fertilization mode where local fertilizer is supplied by volume per minute.

Local fert proportional – Enable or disable fertilization mode where local fertilizer is supplied proportionally.

Local fert bulk by time – Enable or disable fertilization mode where local fertilizer is supplied by bulk of time.

Local fert bulk by volume – Enable or disable fertilization mode where local fertilizer is supplied by bulk of volume.

Default fert mode – Default fertigation dosage mode.

Misc

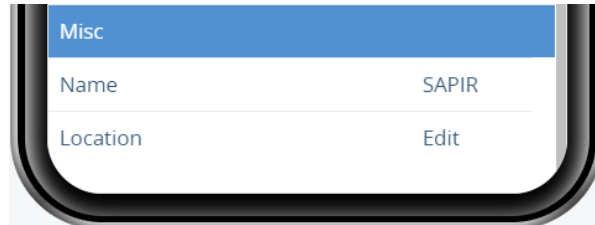

Name – Name of the controller.

Location – set the location of the controller using the GPS on your phone.

Current time – Manual setting of the time of the controller will appear only while using Wi-Fi direct, if the controller is connected to the internet the time will be updated automatically.

22.2 Line



Pointers

1. **Name** – name of the line.

Default water source – Not in use.

Low flow behavior – Setting the reaction of the controller to low flow (**Pointer A**).

Low flow delay (hh:mm:ss) – Setting the response time to low flow.

High flow behavior – Setting the reaction of the controller to high flow (**Pointer A**).

High flow delay (hh:mm:ss) – Setting the response time to high flow.

Leakage limit (pulses/30 min) – Number of pulses per 30 minutes coming from the water meter that will be considered as water leakage while there is no programmed irrigation.

22.3 Main valve

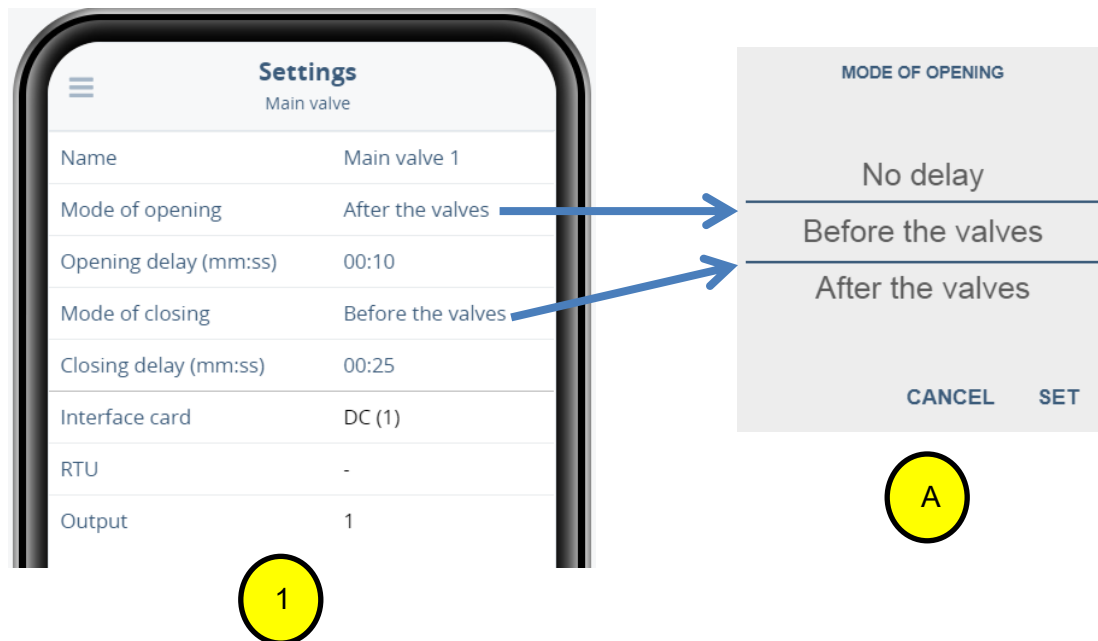

Pointers

1. **Name** – set the name of the main valve.
Mode of opening – When should the main valve open (**Pointer A**).
Opening delay (mm:ss) – in case its Before or After the valves, what should be the delay between them while opening.
Mode of closing – When should the main valve close (**Pointer A**).
Closing delay (mm:ss) – in case its Before or After the valves, what should be the delay between them while closing.
Interface card – to which interface the main valve is related to (viewing only).
RTU – to which RTU the main valve is connected (viewing only).
Output – in which Output the main valve is connected (viewing only).

22.4 Valve

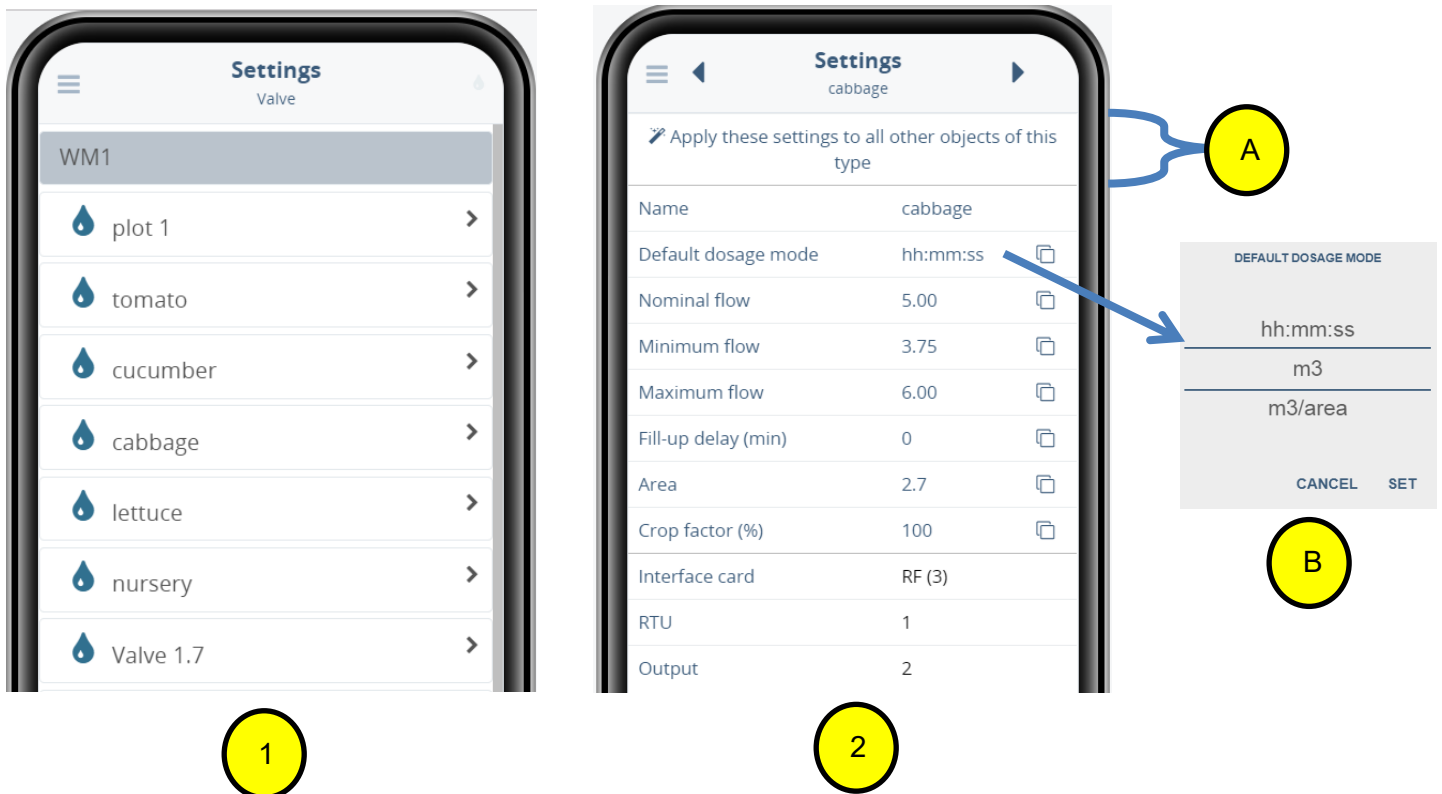

Pointers

1. List of the irrigation valves defined in the controller. In order to modify parameters of a certain valve, tap on it.
2. Valves parameters list:
Apply these settings to all other objects of this type (Pointer A) – set all irrigation valves parameters to be as the current valve.
Name – define the valve name.
Default dosage mode (Pointer B) – set the default water dosing for the valve.

Nominal flow – set the valve nominal flow.

Minimum flow – set the valve minimum flow (uses for low flow alarms).

Maximum flow – set the valve maximum flow (uses for high flow alarms).

Fill-up delay (min) – Fill time in minutes for the current valve, in this period of time the controller is ignoring flow problems of the current valve.

Area – set the area (size in Dunam, Hectar or acre (**system/Defaults**)) irrigated by the current valve.

Crop factor (%) – set the percentage of the programmed water dosage that you want to us, for example, Crop factor 120% and water dosage of 5m³ = 6m³

Crop factor of 80% and water dosage of 5m³ = 4m³

Crop factor of 100% will remain the water dosage as is.

Interface card – to which interface the valve is related to (viewing only).

RTU – to which RTU the valve is connected (viewing only).

Output – in which Output the valve is connected (viewing only).

Note: The  icon uses for duplicating this specific parameter to other sensors.

22.5 Valves group



Pointers

1. List of exciting groups, to edit tap on the desired group, to add new group tap on the 3 lines icon and select **New group (Pointer A)**.
2. **Group name** – set the group name
Valves – tap to set / edit the group valves.
To delete the group tap on the 3 lines icon and select Delete (**Pointer B**).
3. Select / edit and save the valves of the group.

22.6 Water meter

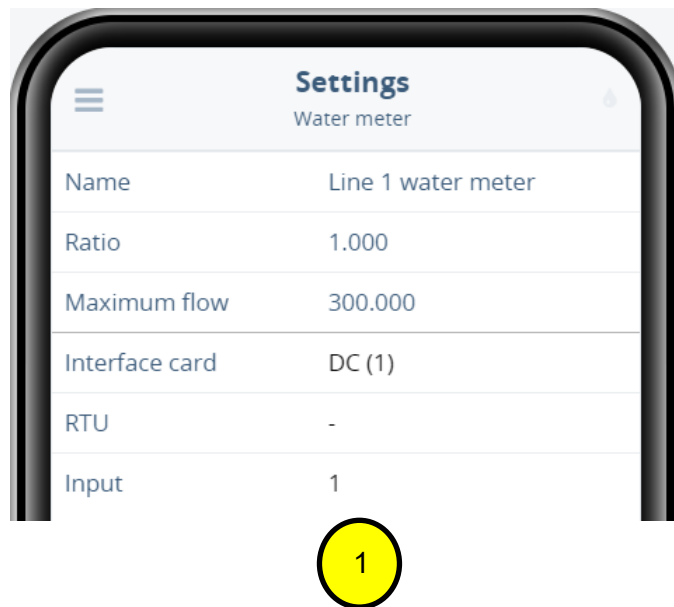

Pointers

1. **Name** – se the water meter name.
Ratio – define the value of each pulse coming from the water meter.
Maximum flow – uses for the water meter icon scale in the maps.
Interface card – to which interface the water meter is related to (viewing only).
RTU – to which RTU the water meter is connected (viewing only).
Output – in which Input the water meter is connected (viewing only).

22.7 Fertilizer

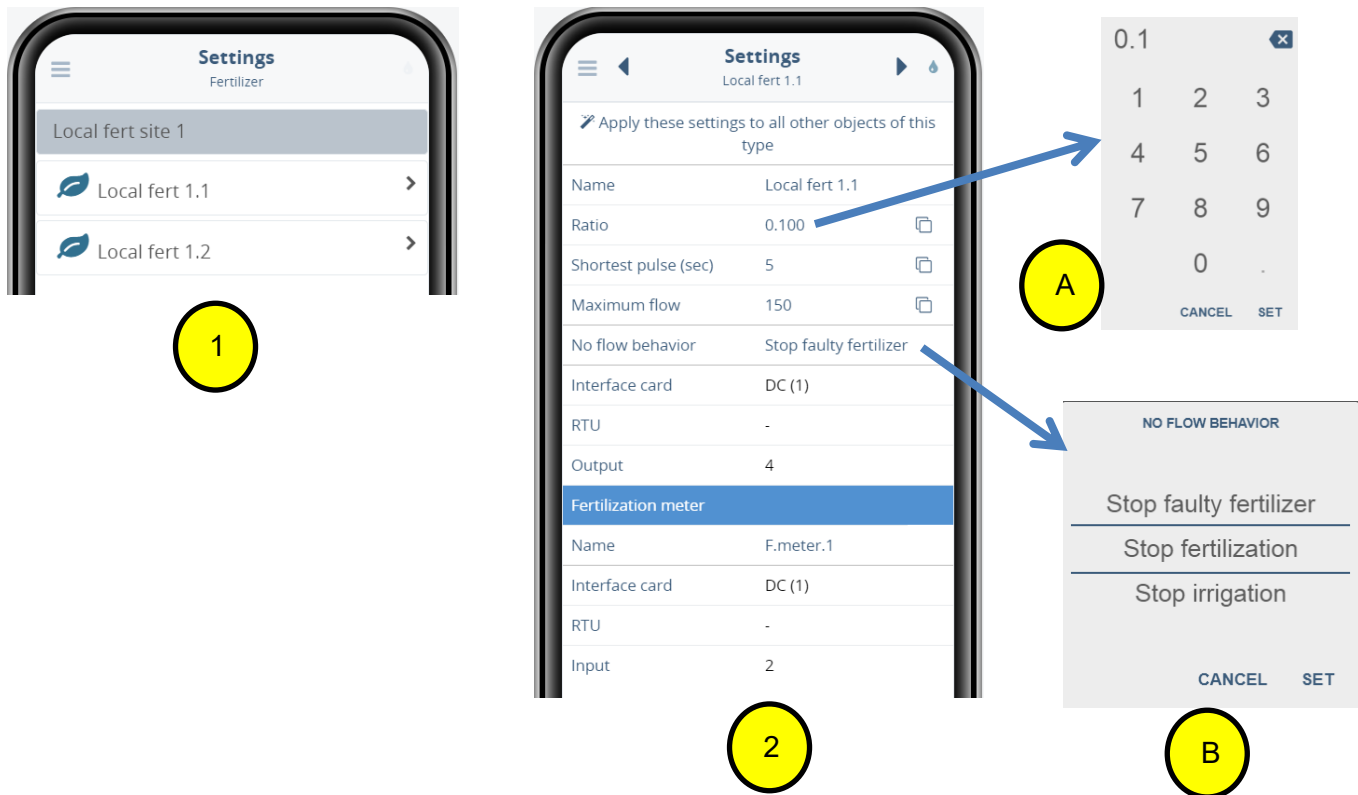

Pointers

1. List of all the fertilizers injectors, to edit the injectors and fertilizer meters parameters tap on the desired fertilizer injector.
2. List of parameters of the fertilizer injector:
 - Apply these settings to all other objects of this type** – set all irrigation valves parameters to be as the current valve.
 - Name** – set the name of the injector.
 - Ratio** – set the ratio (L/pulse) of the fertilizer meter (**Pointer A**).
 - Shortest pulse (sec)** - parameter defines in seconds the time slice by which the fertilizer pulse will be divided in case of time based proportional fertigation. The purpose is to get a better distribution of the fertilizer in the water.
 - “A special case”** – when the fertilizer meter gets damaged, then all the volumetric fertilizer dosages that were defined based on that meter, in all the programs, cannot be used anymore. In order to let the user keep working volumetrically until the fertilizer meter is repaired, he can go and erase the connection of the fertilizer meter from the connections list. This will notify the system that the fertilizer meter is not in use and instead the controller will use the Ratio and the Shortest pulse parameters for converting the volumetric fertilizer dosages into time and thus save the need to redefine all the fertilizer dosages. This of course requires the user to set the Ratio and the Shortest pulse properly so that the Ratio will really indicate the amount of fertilizer that the injector will inject within the time expressed by the Shortest pulse.

No flow behavior - set the reaction of the controller to no flow events in this injector.
Interface card – to which interface the Fertilizer injector is related to (viewing only).
RTU – to which RTU the Fertilizer injector is connected (viewing only).
Output – in which Input the Fertilizer injector is connected (viewing only).

Fertilization meter

Name – set the name of the Fertilization meter.
Interface card – to which interface the Fertilization meter is related to (viewing only).
RTU – to which RTU the Fertilization meter is connected (viewing only).
Output – in which Input the Fertilization meter is connected (viewing only).

Note: The  icon uses for duplicating this specific parameter to other sensors.

22.8 Filtration site

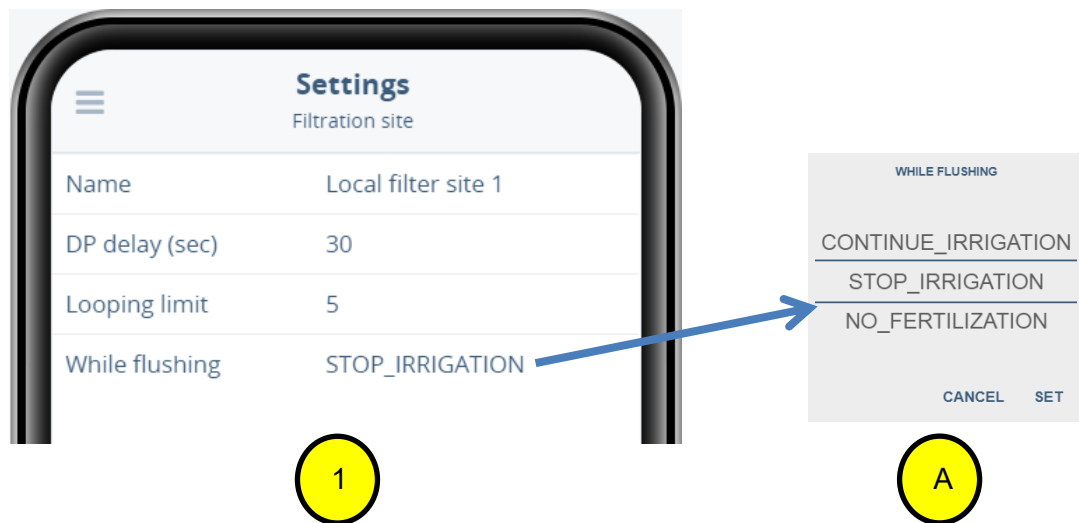

Pointers

- Name** - set the name of the Filtration site.
DP delay (sec) - The reaction delay for a change in the DP status.
Looping limit - The number of consecutive cycles by DP considered as endless looping alarm, for example, after 5 consecutive flushes the controller will send alarm and stop flushing by DP, it will continue back flushing according to the setting time in **Inter-flushing period (page 31/Flushing)** until cancellation of the Looping alarm or a change in the DP status.
While flushing – select from the list (**pointer A**) what the controller should do while flushing.

22.9 Analog sensor



Pointers

1. List of the defined analog sensors, tap on the sensor to change its parameters.
2. List of the sensors parameters:
 - Name** – set the analog sensor name.
 - Type** – select the analog sensor type from the list (**pointer A**).
 - Units** – select the analog sensor units from the list (**pointer B**).
 - Measured by** – select if the sensor is measured by Current or Voltage (**pointer C**).
 - Minimum** – set the minimal value of the sensor's range of values.
 - Maximum** – set the maximal value of the sensor's range of values.
 - Excitation time (milli-sec)** – set the excitation time for the sensor.
 - Reading rate (sec)** – set the reading rate in seconds.
 - Data source** – Externa or Internal, not in use.
 - Interface card** – to which interface the Analog sensor is related to (viewing only).
 - RTU** – to which RTU the Analog sensor is connected (viewing only).
 - Output** – in which Input the Analog sensor is connected (viewing only).

Note: The  icon uses for duplicating this specific parameter to other sensors.